

HOPKINS & ALLEN GUNS

By Paul Berg
Copyrighted - 1969



PAUL O. BERG

This opportunity to talk at our El Paso meeting about Hopkins and Allen guns is most appropriate. Back in the turbulent years following the war between the states, tons of firearms passed through our borders into Mexico and other countries to the south and El Paso was an important border town for this export. In 1880 the firearm companies located in Norwich, Connecticut alone were making over 1,000 pistols a day and Hopkins and Allen Mfg. Co. was one of the most prolific makers with a thriving export business through Merwin, Hulbert & Co.

Today a dribble of the initial flow has reversed, coming back to the United States as collector's items and interestingly enough selling over ten times the original price. No dribble is evident of the large export to Russia.

The years the founders of the company were to span was 1857 to 1916, nearly 60 years, a period that began with muzzle loaders, went through the black powder cartridge development and ended in the smokeless powder guns of the first World War era.

To keep this dissertation in proper order certain specific topics will be covered in the following sequence:

1. Company History
2. Associated Companies
3. Significant Patents
4. Outstanding Models
5. Conclusions

HISTORY

Brothers Charles W. and Samuel S. Hopkins were two enterprising young men who had found an outlet for their mechanical talents in gunsmithing. Charles, Fig. 1 is known to have worked as a gunsmith for Allen & Thurber, Bacon and Manhattan F.A. Co. A Charles H. Allen had associated with the Hopkins as a gunsmith in 1857 so in 1867 with the purchase of the Bacon Mfg. Co. building at "the Falls" near Norwich the three established the Hopkins and Allen Manufacturing Co. with a capital of \$6,000 and 12 employees. Henry H. Hopkins, Fig. 2 also listed as an employee of Allen & Thurber, gun makers in Norwich prior to 1847 can be assumed to be the Henry H. Hopkins who was to contribute several minor patents used by the company but it is known that Henry found his main interest in farming.

In 1878, in need of larger quarters, the factory moved to the corner of Willow and Franklin St., Norwich, Fig. 3 & 4, where an Edwin Allen had been operating the Allen Spool and Printing Co. A Frank P. Allen had been listed as a mechanist at this address as early as 1868. A Frank H. Allen, attorney, son of Charles Allen, appears on some company owned patents as attorney and also as inventor of four patents. There may have been other Hopkins or Allens who took part in the firm's activities but do not appear in the records.

Those outside the families who were active in company affairs were; Horace A. Briggs, president 1868 to 1897, A. H. Brewer, president 1910, John McGreagor, president 1916 and John E. Warner, secretary. Col. Charles A. Converse was very early influential in Bacon as well as Hopkins and Allen operations.

In 1898, after Merwin, Hulbert & Co. had ceased operations,



the name was changed to Hopkins and Allen Firearms Co. and the firm became a sole operator in the firearms field. Acquisition had been made of the Forehand & Wadsworth Co. The Davenport Co., Ethan Allen. This was the end of the spur trigger models and an excellently made Safety Police hinged model was now produced in revolver, target and buggy rifle style.

In February 1900, a fire destroyed the plant but with confidence in the future the firm rebuilt Fig. 5, and by 1904 was producing 188 models of revolvers, rifles and shot-guns with export to major countries throughout the world. Employment numbered 600.

The last important production was a Mauser rifle made for Belgium prior to the German invasion of that country in 1914. The company was then acquired by Marlin-Rockwell Arms Co. who were in machine gun production. The rights to the company name was acquired by Numerick Arms who today offer Hopkins & Allen guns of modern manufacture.

It was ironic that a company who had survived fires, depressions, panics should fold at the beginning of a great war with so much demand for military production but management must have lacked aggressive young leadership. The last catalog noted is dated 1914. The last city directory listing was 1916.



CHARLES W. HOPKINS

ASSOCIATES

The flexibility of the firm's operations is evident by the variety of companies who were associates either as distributors or as users of the firm's gunsmithing know-how. The most intimate and in both categories was the Merwin, Hulbert & Co. who were known to hold stock in the firm and who featured Hopkins and Allen guns in their catalogs from the first in 1874 (in Spanish) up till 1892 when they ceased operations.



HENRY H. HOPKINS

In 1876 the Merwin Hulbert revolver took part in the Army trials and although not accepted the report praised the workmanship, a compliment to the Hopkins and Allen Co. This model was from then on a part of the line that was offered by Merwin & Hulbert Co.

Spencer, Bartlett & Co. who carried the name Rev-No-Vac on rifles made for them by Hopkins and Allen. The firm had started making rifles in 1888.

Firms who acted in the category of distributors, authenticated either by stampings on the guns or by listing in catalogs are as follows:

- Western Gun Works, Chicago, Illinois
- Black & Owen, Detroit, Michigan
- Toledo Fire Arms Co., Toledo, Ohio
- James Bown & Son, Pittsburgh, Pa.
- J. A. Ross & Co., Boston, Mass.
- J. H. Johnson, Pittsburgh, Pa.
- Schoverline & Daly, New York, N.Y.
- J. A. Richard & Co., Schenectady, N.Y.
- The Essex Repeating Arms Co., Boston, Mass.
- C. D. Meacham Arms Co., St. Louis, Mo.
- The Pickering Hardware Co., Cincinnati, Ohio

Firms who made use of the company's expert gun making experience can be listed as follows:
A repeating shotgun patented April 10, 1866 by S. H. Roper bears the Hopkins and Allen stamping as manufacturer.

The Evans Repeating Rifle, Mechanics Falls, Maine, patented Dec. 8, 1868 and Sept. 19, 1871 was reputedly made by Hopkins and Allen.

C. W. Turner & Ross, Boston, Massachusetts advertised their Czar revolver which was made by Hopkins and Allen. The gun grips have in place of the conventional dog's head the T & R engraving.

A revolving rifle called the Chichester is typically Hopkins and Allen and carries their patent dates. This firm, called the Chichester Rifle Co., was incorporated in 1880 and was listed in the Jersey City, N.J. directory in 1881 at 31 Montgomery St.

In 1884, J. A. Ross & Co. offered a similar stocked rifle called The Challenge.

SIGNIFICANT PATENTS

Before discussing models it is apropos to become familiar with the company controlled patents that influenced design. The patent use usually covers a definite period thus indicating by date the start of the period. By recognizing the patent it is possible to immediately recognize the manufacture. The uniqueness of the patent indicates a company's contribution to the advancement of an industry. Employees participation in patents is a barometer of loyalty and interest. The following is a list of the most outstanding patents used:

Fig.	Number	Date	Inventor	Patent Claim
6	35,419	5-27-62	C. W. Hopkins	Swing out cylinder
7	41,117	1-5-64	Briggs & Hopkins	Swing out cylinder
8	57,622	8-28-66	Converse & Hopkins	Pepperbox with ring retainer
9	101,637	4-5-70	J. M. Marlin	Single shot derringer ejector
10	113,053	3-28-71	S. S. Hopkins	Swing out cylinder, side action cylinder pin catch
11	243,012	9-23-73	H. H. Hopkins	Hinged breech block
12	157,860	12-15-74	D. Moore	Barrel revolves on frame
13	162,475	4-27-75	H. H. Hopkins	Safety cylinder
14	165,098	6-29-75	C. W. Hopkins	Cylinder pin as safety catch
15	168,549	10-11-75	F. H. Allen	Cylinder pin hammer latch
16	187,975	3-6-77	W. A. Hulbert	Ejector and gate part of recoil shield
17	187,980	3-6-77	D. Moore	Barrel revolves on frame
18	297,801	4-29-84	S. S. Hopkins	Ejector mounted on cylinder pin
19	311,323	1-27-85	S. S. Hopkins	Hinged hammer
20	390,286	10-2-88	W. H. Davenport	Adjustable set trigger
21	505,569	9-26-93	Hopkins & Boland	Hammerless safety catch
22	829,082	8-21-1906	J. J. Murphy	Cam mounted hammer for safety

An interesting observation, the first three patents were issued before the formation of the company and these patents were used by Bacon which had been established in 1862. These patents were never used by Hopkins and Allen Manufacturing Co.

The 1870 patent by J. M. Marlin is recognized as the XL Derringer by Hopkins and Allen and the patent date will be found on the derringer.

The 1871 patent is most important because this mentions the cylinder pin catch located on the side of the frame, a feature that identifies the firm's product and one that existed through the entire production of spur triggers from 1871 up to 1900 and was even incorporated in the double action models. The swing out cylinder claim in this patent was used on the XL-6 model Fig. 23 which has proven to be very rare.

The 1873 hinged breech block patent was used on the X-Pert, another model which has proven to be very rare.

The Daniel Moore and W. A. Hulbert patents cover the revolving barrel model that is known to collectors as the Merwin Hulbert. The tricky mechanism to disassemble the gun puzzles the uninitiated.

The 1875 patents were all directed towards safety. The safety cylinder is an excellent identification of the company's product and was so faithfully used on most models.

The 1884 patent is an ejector similar to that used by Colt except the entire ejection mechanism is mounted on the cylinder pin and removes with the pin, a simple method of accomplishing the end result. Few of these models exist.

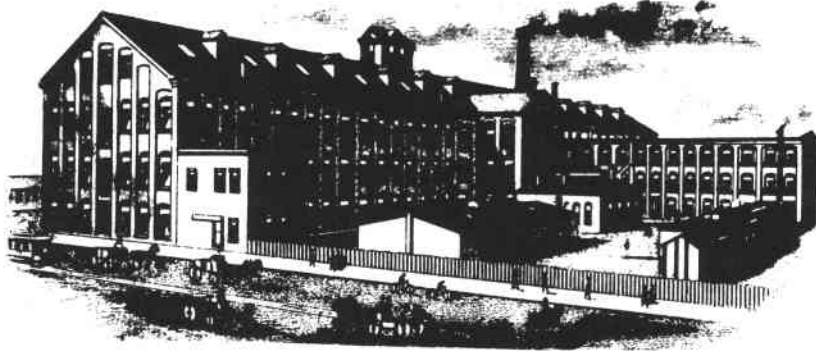

Fig. #3 FACTORY AT WILLOW AND FRANKLIN STREET

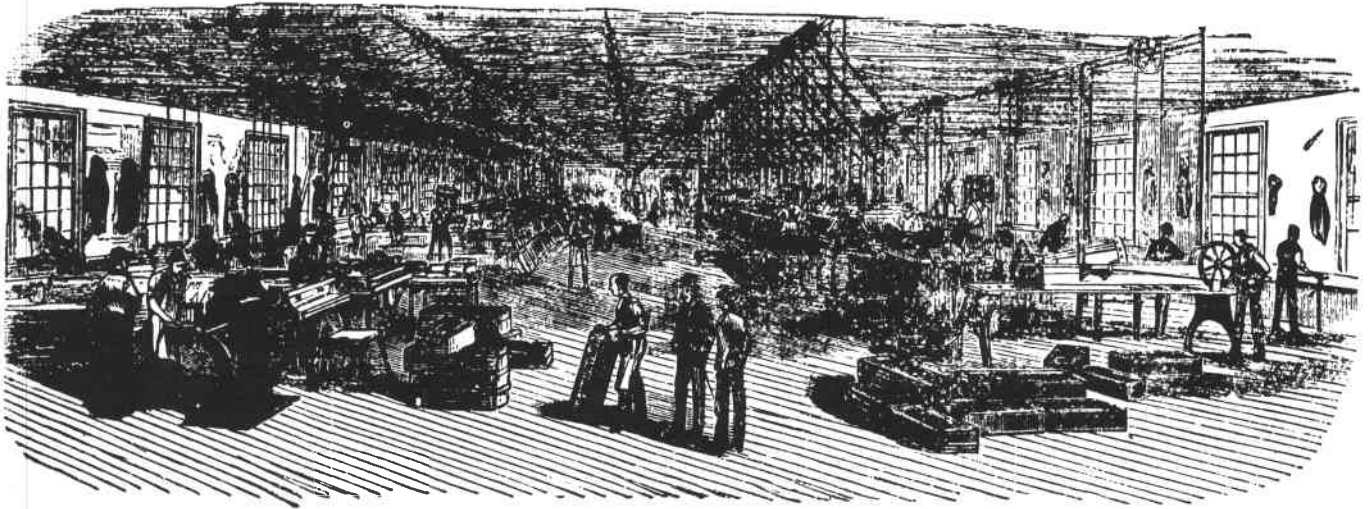

Fig. #4 MANUFACTURING THE "CZAR" REVOLVER AT THE NORWICH FACTORY

Fig. #5 NORWICH FACTORY AS RE-BUILT AFTER 1900 FIRE

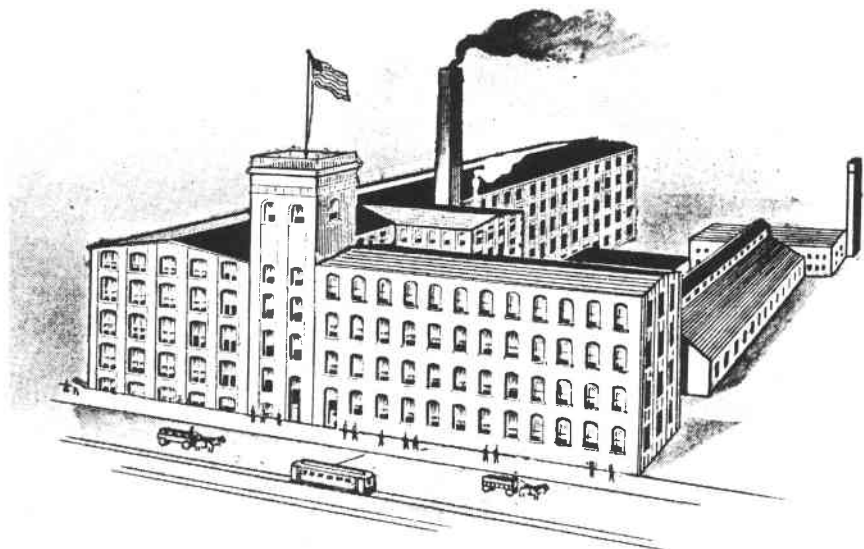
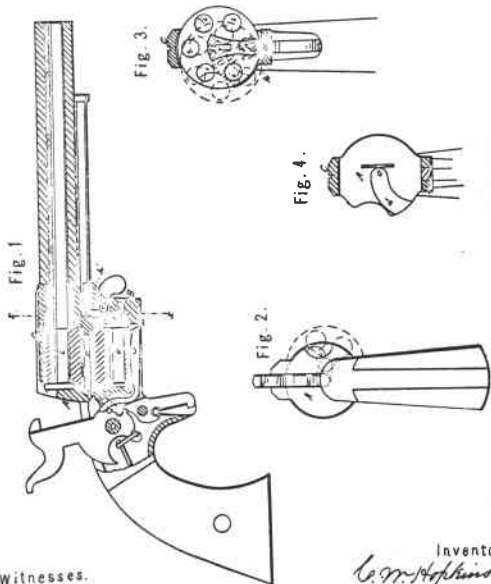

Fig. #6

C. W. HOPKINS.
Revolver.

No. 36,419.

Patented May 27, 1862.



Witnesses.
J. W. Brown
M. M. Linn

Inventor:
C. W. Hopkins
per *M. M. Linn*
Attorneys.

U. S. PATENT OFFICE, WASHINGTON, D. C.

CONVERSE & HOPKINS.
Revolver.

No. 37,822.

Patented Aug. 28, 1866.

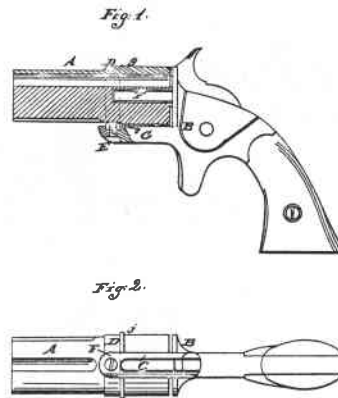

Witnesses:
J. M. Brington
W. E. Ewin

Inventors:
Chas. A. Converse
Saml. S. Hopkins
per *Wm. M. Linn*
Attorneys.

U. S. PATENT OFFICE, WASHINGTON, D. C.

H. A. BRIGGS & S. S. HOPKINS.
REVOLVING FIREARM.

No. 41,117.

Patented Jan. 5, 1864.

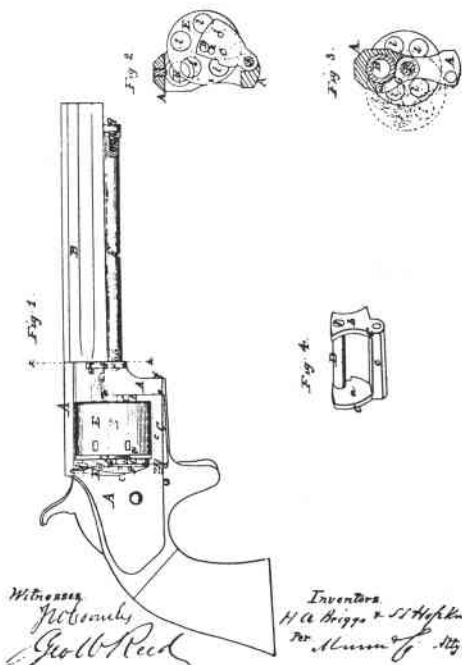

Witnesses:
J. W. Brown
Geo. W. Reed

Inventors:
H. A. Briggs & S. S. Hopkins
per *M. M. Linn*
Attorneys.

Fig. #7

J. M. MARLIN.
CARTRIDGE EJECTOR.

No. 101,637.

Patented Apr. 5, 1870.

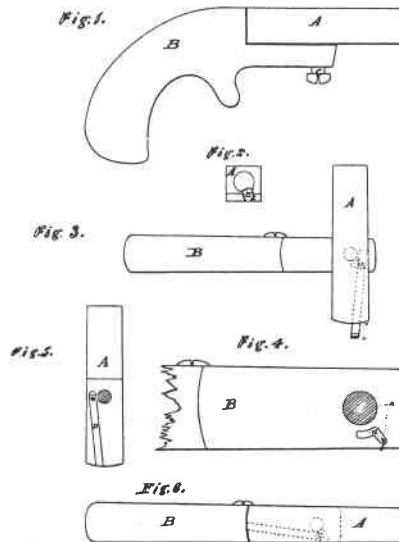

Witnesses:
Wm. M. Linn
Chas. Brown

Inventor:
J. M. Marlin
per *Chapman Hosmer & Co*
Attorneys.

U. S. PATENT OFFICE, WASHINGTON, D. C.

Fig. #9

Fig. #10

S. S. HOPKINS
Revolving Fire-Arm.

No 113,053. Patented March 28, 1871.

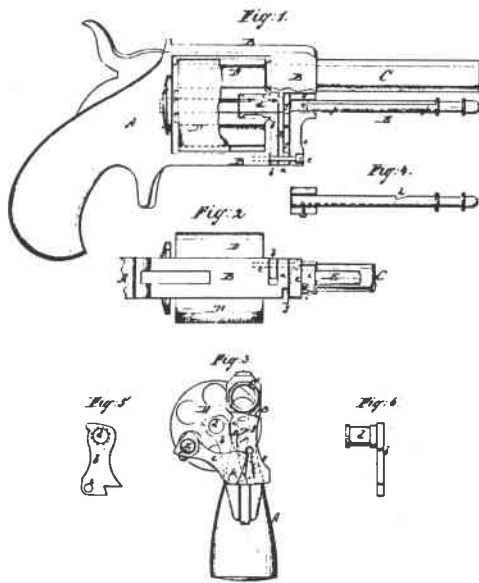

Witnesses:

J. P. Smith
J. P. Smith & Co.

Inventor:
S. S. Hopkins

Wm. S. ...
Attorneys.

NO. 113,053—MAY 1871

Fig. #12

D. MOORE.
Revolving Fire-Arm.

No. 157,860 Patented Dec. 15, 1874

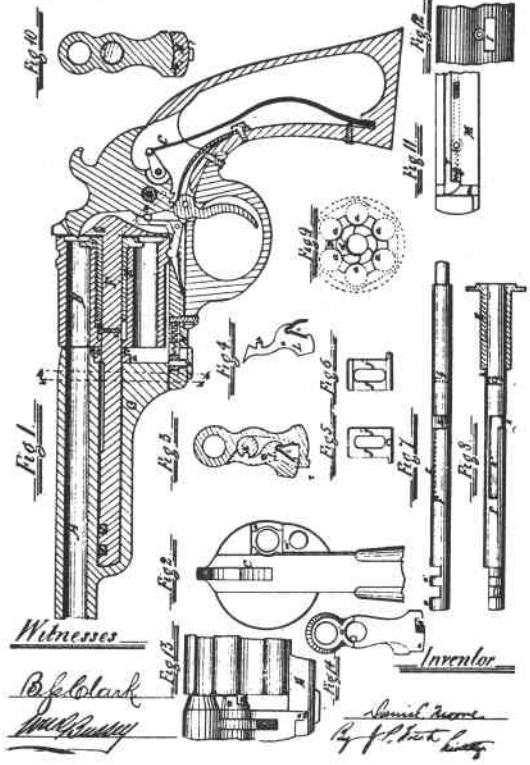

Witnesses

B. J. ...
...

Inventor

...
...

NO. 157,860—DEC 15 1874

H. H. HOPKINS.
Breech-Loading Fire-Arms.

No. 143,012. Patented September 23, 1873.

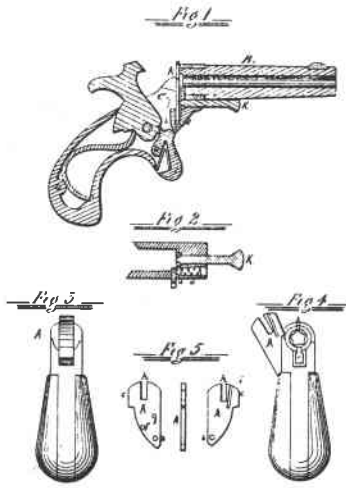

Witnesses
Samuel A. Hopkins
...

Inventor
Henry H. Hopkins

NO. 143,012—SEP 23 1873

Fig. #11

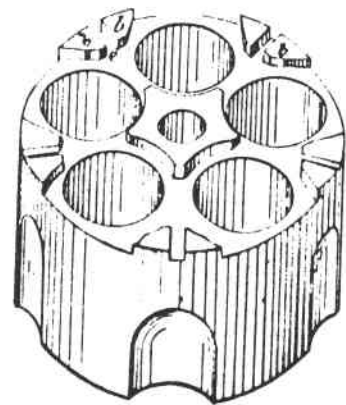
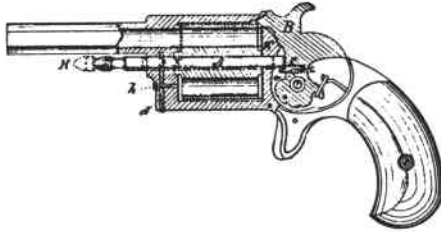

Fig. #13

Fig. #14

C. W. HOPKINS.
Safety-Catch for Revolvers.
No. 165,098. Patented June 29, 1875.



Witnesses:
Henry ...
John ...

Inventor:
C. W. Hopkins

THE GRAPHIC OR PHOTO-LITHO PRINT PROCESS

Fig. #16

W. A. HULBERT.
REVOLVING FIRE-ARMS.
No. 187,975. Patented March 6, 1877.

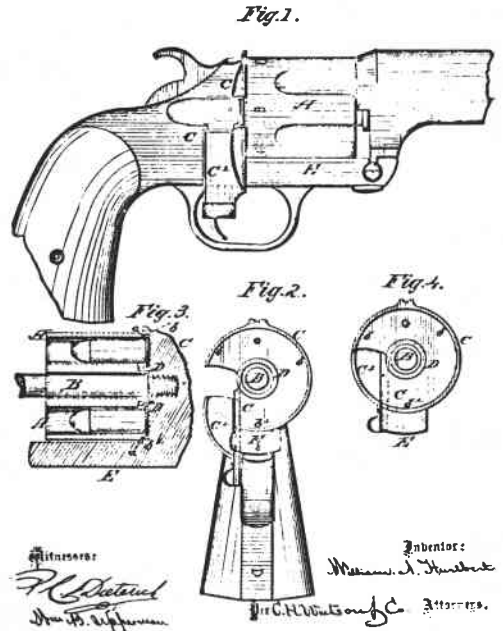

Witnesses:
P. D. ...
...

Inventor:
W. A. Hulbert
By *C. H. Watson & Co. Attorneys.*

THE GRAPHIC OR PHOTO-LITHO PRINT PROCESS

F. H. ALLEN.
Locking-Catch for Revolvers.
No. 168,549. Patented Oct. 11, 1875.

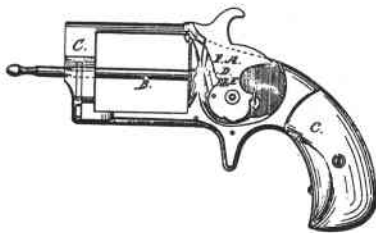

Witnesses:
John ...
...

Inventor:
Frank H. Allen

THE GRAPHIC OR PHOTO-LITHO PRINT PROCESS

Fig. #15

D. MOORE.
REVOLVING FIRE-ARM.
No. 187,980. Patented March 6, 1877.

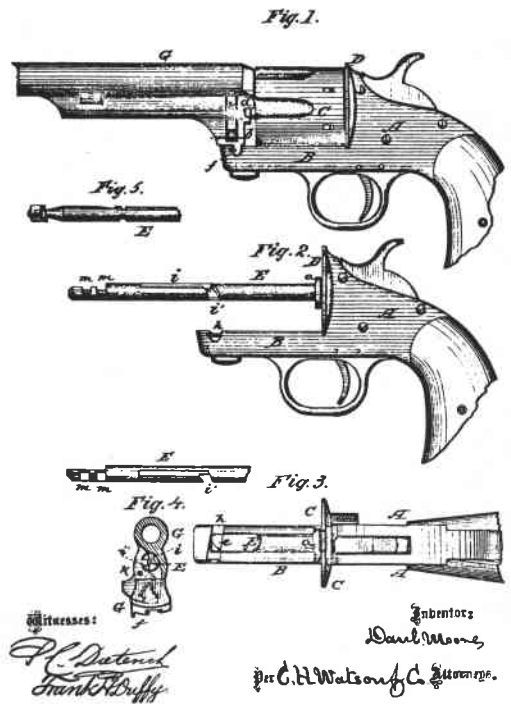

Witnesses:
P. D. ...
Frank ...

Inventor:
Daniel Moore
By *C. H. Watson & Co. Attorneys.*

THE GRAPHIC OR PHOTO-LITHO PRINT PROCESS

Fig. #17

Fig. #18

(No Model.)

S. S. HOPKINS.
REVOLVER.

No. 297,801.

Patented Apr. 29, 1884.

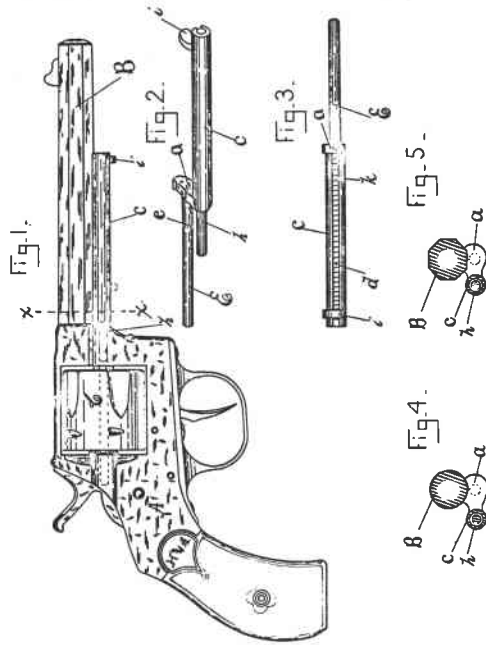

WITNESSES
L. Ashbel Brandt,
G. P. Kimball

INVENTOR,
Samuel S. Hopkins
 By his Attorney
Frank H. Allen

Fig. #20

(No Model.)

W. H. DAVENPORT.
SET TRIGGER FOR FIRE ARMS

No. 300,280.

Patented Oct. 2, 1888.

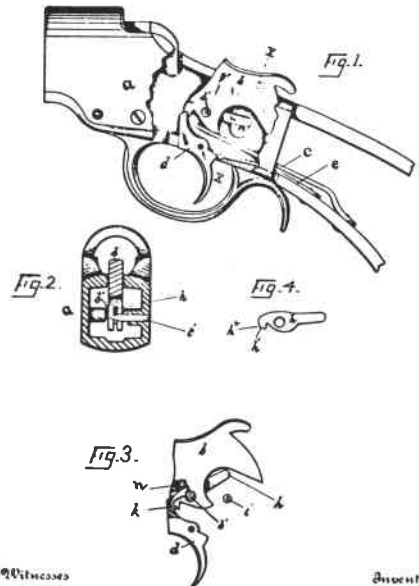

WITNESSES
Allen Tenney
Henry H. Sutherland

INVENTOR
William H. Davenport,
 By his Attorney
Frank H. Allen

(No Model.)

S. S. HOPKINS.
HAMMER FOR FIRE ARMS.

No. 311,323.

Patented Jan. 27, 1885.



Witnesses—
Eyles J. Howard,
George W. Moore.

Inventor—
Samuel S. Hopkins
 By his Attorney
Frank H. Allen

(No Model.)

C. W. HOPKINS & J. BOLAND.
SAFETY OATCH FOR FIREARMS.

No. 505,569.

Patented Sept. 26, 1893.

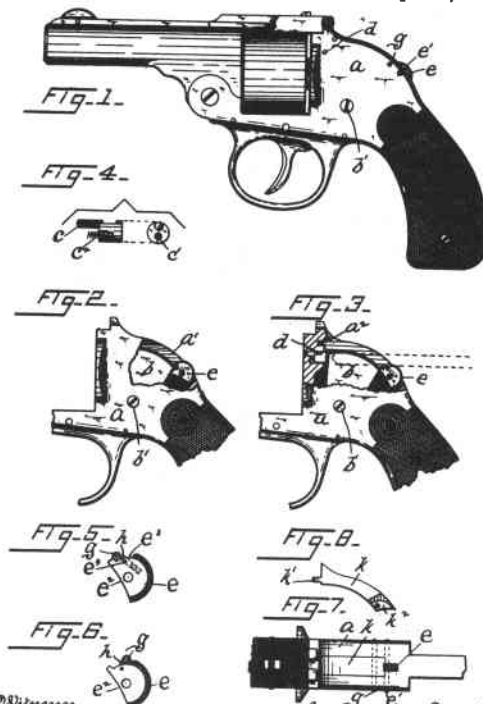

Witnesses
Allen Tenney,
Charles H. Luther.

Inventors:
Charles W. Hopkins,
James Boland
 By Attorney
Frank H. Allen

Fig. #19

Fig. #21

Fig. #22

Fig. #24

No. 829,082

PATENTED AUG. 21, 1906.

J. J. MURPHY.
FIREARM.
APPLICATION FILED APR. 8, 1904.

Fig 1

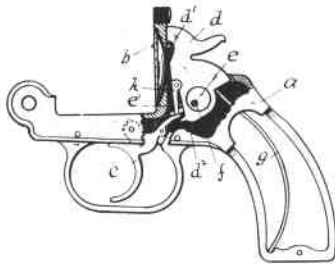

Fig 2

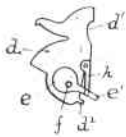
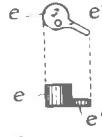

Fig 3



Witnesses
Frank C. Palmer
Madeline D. G. [illegible]

John J. Murphy Inventor,
by Frank H. Allen
Attorney



Fig. #23



Fig. #25

The 1885 patent claims a hinged hammer which was the answer to the hammer catching to the pocket. Once fired the hinge returns automatically to safe position. This feature was optional.

The 1888 patent by W. H. Davenport was a set trigger arrangement adjusted by a screw located in the side of the frame. This feature is found on Hopkins and Allen long guns as well as the drop block action which originated with Davenport.

The hammerless model was called the Acme and to answer the need for a safety the 1893 invention was patented. Another safety feature was the 1906 patent, a method of mounting the hammer pivot on a cam actuated by the trigger. Unless the trigger was in pulled position the hammer will not strike the firing pin.

There were many other patents owned by the company but were not noticed on models and have been assumed not put to use.

OUTSTANDING MODELS

With the history of the company and the important patents in mind it is now possible to examine the different models with a better understanding as to the period and the identification.

The first gun made undoubtedly was a muzzle loading pistol, offered in 4 or 5 inch barrel and 31 calibre. This is shown in Fig. 24. The barrel bears the stamping HOPKINS & ALLEN MFG. CO. NORWICH CT. so by deduction this was produced in 1868 or later. At this time there was still a market for the cap and ball guns. The die rolled on the cylinder is identical to that used by Bacon and Manhattan proving cooperation between the firms.

An interesting pair is shown in Fig. 25. The upper one is marked Bacon Mfg. Co., Norwich, Conn. and the Lower one Hopkins & Allen Mfg. Co., Norwich, Ct. These guns are nearly twins and certainly further proven inter-relationship of the two companies. The 1871 patented cylinder catch is not used so the manufacture must have been prior to this date. Note the half round, half hexagonal barrel with knurled band between and the round frame, characteristics of early models and a frame that was to be on later models.

A James Bohn catalog shows, Fig. 26 a front cylinder pin latch and round frame. This dates the catalog prior to 1871. This XL 4 in 38 cal. was to continue as a main line for many years. The same round frame shape was offered in this catalog as the LX 3 in 32 calibre and has the half round, half hexagonal barrel. A similar specimen exists in 4" barrel with no model marking but bears the same company stamping on the side of the barrel as the muzzle loading pistol. Another specimen in 32 calibre and 3" barrel bears the stamping XL No. 3 N.Y. The later XL 3s were not with round frames so this shape must represent the period before 1871. An illustration from a Merwin Hulbert catalog (Spanish) of 1874, Fig. 28 shows the flat frame. The XL-5, Fig. 27 is from the same catalog.

Before going further into discussion of models it has been observed that strict adherence to models conforming to names does not seem to exist. An XL-1 has been observed in four varieties and the Blue Jacket 1 in three varieties. Some models do not have the side cylinder pin catch but use a pin threaded at the end to screw into the frame. Because of the rotation of the cylinder the pin has left hand threads. The XLs were called the company's better product and an examination reveals this. Generally the larger calibre guns appear better made than, for instance, the 22 cal. models.

Some models were made in large frame which is evident in the space between trigger and hammer. The XL calibres by number are as follows: #1 - 22 cal., #1-1/2 - 22 cal., #2 - 30 cal., #3 - 32 cal., #4 - 38 cal., #5 - 38 cal., #6 - 41 cal., #7 - 41 cal., and #8 - 44-40 or 44 Henry cal., The Blue Jackets ran: #1 - 22 cal., #1-1/2 - 22 cal., and #2 - 32 cal. An advertisement states that the safety lock feature, patent #165,098, was available on the XL-2, 3 and 5. Other XLs were: XL Navy, XL Police and XL Bulldog.

Early models have a distinguishing feature of no loading slot in the recoil shield and all early models have higher hammers. The 22 cal. early models have pin front sights.

The serial numbers include a letter which is an identification of the model. Numbers have not been noted above four digits.

Most guns were nickle plated and blued finish was offered 50¢ extra so the blued variety is less common. The engraving varied in quality, some specimens are exquisitely done with delicate curves showing artistry of the highest form while others are skimpily engraved and much of it dimpled marks to give the impression of engraving. One form of engraving, not noted supplied by any other gun manufacture was deep cut scrolls with the cut filled in with colored enamel. Over the years this enamel came out of most specimens giving

Fig. #26

10 JAMES BOWN & SON'S WHOLESALE PRICE LIST

XL No. 4, OR POLICE CARTRIDGE REVOLVER.

To all who need an effective weapon, we confidently recommend the Police Revolver as the best; of heavier Caliber than any other Pocket Revolver, and of the same capacity as the best of the same Caliber. With finished, perfect in construction and always effective. We get these Pistols up with Ivory or Pearl Stocks, finely Engraved and Silver and Gold Mountings.

Calibre Larger than Colt's Navy Revolver.

Blued - Price \$8 50
Full Plate, " 9 50

Exact Size Weight 3 oz.
Five Shots,
38-100 CALIBRE.

Fig. #28

XL REVOLVER. No. 5.

CON CILINDRO DE SEGURIDAD.

Calibre de 11, 2, 24 y 3 Pulgadas.

Nickel plated, grabado, con culata de Nacar.

XL REVOLVER. No. 3.

CON CILINDRO DE SEGURIDAD.

Calibre de 11 Pulg., 2 Pulg., 24 Pulg. y 3 Pulg.

Nickel plated, grabado, y culata de marfil.

Fig. #27

POINTER. Single Shot. Break loader. 22-100 Cal.
Price, \$1.50.

XL DERRINGER. 41-100 Cal.
4 Service Weapons for Execution. Per Pair, \$2.00.

BONNIE BLUE. Blank Cartridge. 22-100 Cal.
Price, per pair, \$1.

XL VEST POCKET. 22-100 Cal.
Amateur and Long Range. Price, \$1.50.

Fig. #29 & #30



New Model Skeleton Stock Target Pistol



New Model Vest Pocket Derringer



HOPKINS & ALLEN
Single Shot Target Pistol

22 Calibre, 10-inch Barrel Nickel or Blued
Shoots 22 long rifle smokeless cartridges

PRICE
\$10.⁰⁰

Fig. #32

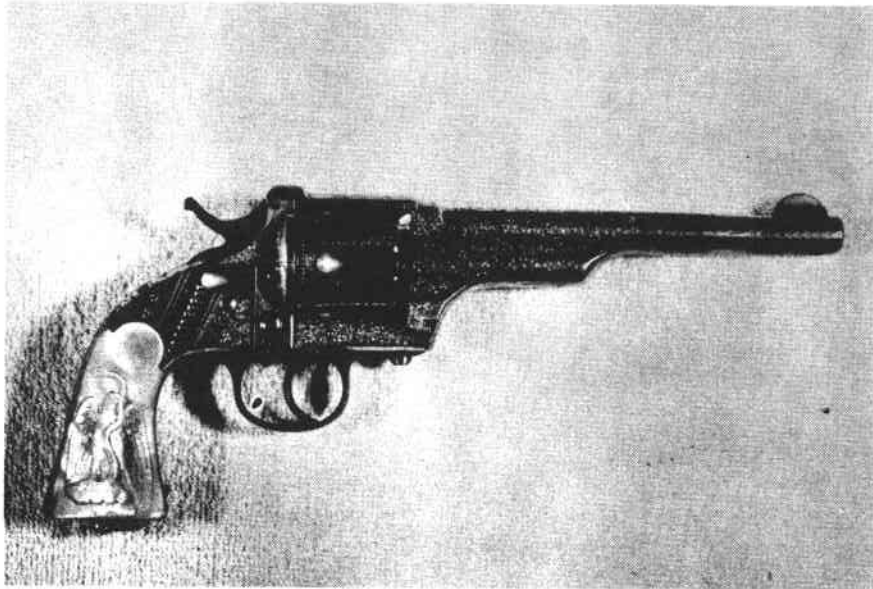

Fig. #33

Fig. #31

an unsightly appearance but where it has remained the beauty can be appreciated and was a desirable decoration. Gun grips were found in rosewood, walnut, pearl, ivory and a form of plastic in solid or moulded colors.

The firm used names on their guns and the following list has been authenticated, either by actual specimens or from catalogs:

Czar	Tramps' Terror	Excelsoir
Range Model	Capt. Jack	Essex
Dictator	Ranger No. 2	Ranger 22 Long
Scott	Hinsdale	Mountain Eagle
The Challenge	Bull Dog	Life Guard
Old Hickory	Safety Police	Towers Police
Buckeye	Acme	Morley
Wolverine		

In addition to the revolvers the single shot derringers, Figs. 29 were supplied as follows: XL - 41 cal., Pointer - 22 cal. and 30 cal. Star or XL Vest Pocket - 22 cal. The derringers are less common than revolvers. A single shot 22 cal. blank pistol called the Bonnie Blue is shown Fig. 30. Specimens of this gun are rare.

The guns shown in Fig. 31 and 32 are from the 1914 Hopkins and Allen catalog and although these come from the tail end of the company's production and should be common they are actually much rarer than earlier models, particularly the Vest Pocket Derringer.

An example of a nicely engraved Merwin Hulbert is shown in Fig. 33. The gun bears the following information CALIBRE WINCHESTER 1873.

CONCLUSIONS

As an area for collector's interest the Hopkins and Allen guns offer a wide variety for exploration and study. There is much evidence of the company's flexibility to produce a wide spectrum of quality from a very excellent to a very cheap product. Probably their interest in satisfying the market for something cheap stamped their image as makers of cheap guns. Anyone familiar with present production methods directed at low cost can admire Hopkins and Allen for their ability to achieve this end without automation, data processing and other aids now available. This low cost product undoubtedly influenced their popularity as an export item.

Credits:

John Hintlian - Catalogs
H. H. Thomas - Photo Fig. 33