

Arms Makers in the Pioneer Valley

John D. Hamilton

As a middle segment of the whole Connecticut River Valley system, the corridor of what is regarded locally as the Pioneer Valley may be said to extend from the falls at Windsor, Connecticut, to the Vermont/New Hampshire border. This region also extends eastward to the present-day Quabbin Reservoir and westward to the edge of the Berkshires, encompassing the layered western Massachusetts counties of Franklin, Hampshire, and Hampden. A mountain belt borders the valley of the Connecticut on the east and on the west. The two great belts converge on each other in the northern part of the state, until above Greenfield their masses almost interlock, while to the south, they separate into a broad valley.

Along its run through the valley, the Connecticut River is fed from the east and west by numerous streams and small rivers, which since settlement early in the seventeenth century have provided abundant waterpower for the region's inhabitants. Arms-making centers were initially established where that waterpower was plentiful and where power wheels would not be subject to destruction by floods or freshets. The rivers and streams were dammed to create reserve ponds that would ensure a reliable and controllable water supply. Hence, shops were not established directly on the Connecticut River, but appeared along the Connecticut's feeder rivers and streams such as the Mill River in Springfield, the Chicopee River, the Westfield River, and its branches, the Green River, the Deerfield River, and the Scantic River. Prior to the Civil War, machine-generated steam power was introduced at a number of arms manufacturing centers to augment or replace water turbine driven machinery so that proximity to a source of water power was no longer a manufacturing necessity. The American Machine Works in Springfield was such an example, being a leader in the field of steam-engine manufacturing as well as a contractor for the production of cavalry carbines and revolvers.

In attempting to identify arms makers who worked in The Pioneer Valley, sometimes referred to in the firearms trade as "Gun Valley," one may cite numerous makers and manufacturers of firearms, ordnance, edged weapons, ammunition, munitions, and military accoutrements. The list I have been compiling for the past six years also includes individuals who filed arms-related patents while residing in the valley, regardless of whether or not their patents were ever placed into production. Currently this list includes about 350



entries. A small number of noteworthy employees of the Springfield Armory and other local arms manufactories, such as John C. Garand, William Jenks, or Willard Milton Farrow, have been included if they were principally responsible for the design of a particular arm and were resident in the valley during some phase of its development and production. Shop workers employed in making arms constituted a large work force whose labors often went unheralded and remain so in my list, unless they achieved a special noteworthy endeavor that set them apart from their coworkers, such as arms engravers Silas Mossman, Jr. and Richard Bates Inshaw, Sr. (1805-1865), or powder flask die sinker and inspector, Richard Paine.

The earliest record that an armorer was active in the Pioneer Valley region is to be found in the records of the Massachusetts Archives (*Indian Papers*, vol. 70:66:89). In 1682, Major John Pynchon, military commander at Hadley, sent gun locks to Hartford to be repaired by Thomas Burnam, who was followed by a number of his descendants who were also gunsmiths. However, seventeenth-century settlers of the Pioneer Valley were forced to rely upon the authorities in Boston to send them arms, gunpowder, and lead for bullets. With the exception of Burnam, it appears that there were only regional craftsmen, such as indentured Scottish rebel John Stewart (d. 1690), who were capable of repairing and

maintaining firearms, but who did not make complete arms as a profession. Throughout the remainder of the Colonial period, and up to the opening salvos of the American Revolution, a few individuals such as Ebenezer (1669-1754) and Seth Pomeroy (1706-1777) of Northampton, and Joseph Chapin (1718-1803) of Longmeadow, were conspicuous in their ability to make or repair a firelock. However, by the time of the Revolutionary War, the ranks of the Valley's capable gunsmiths had expanded to include Isaiah Eaton (1757-1847) of Springfield, Enoch Putnam of Granby, and Richard Falley, Jr. (1740-1808) of Westfield, among others.

The fruitful seed of the Valley's arms industry was sown on December 30, 1776, when Congress directed that General Schuyler, Commander of the Northern Army, cause an "elaboratory [magazine and laboratory] to be erected . . . to fix all necessary ammunition for the ensuing campaign." The site chosen was Brookfield, but four months later that decision was rescinded and instead, "a magazine sufficient to contain 10,000 stands of arms and 200 tons of gunpowder, and a laboratory adjacent thereto," was to be erected in Springfield. (Lewis) Thus it was that in Springfield, in a barn rented from Ebenezer Stebbins, cartridges were filled or renewed, and gunpowder was stored. The temporary laboratory quickly expanded to become a storage center for muskets, cannon, flints, powder, tents, and lead ball. Massachusetts funds subsidized the rebuilding of a powder mill on the Mill River, which quickly gained a reputation for making good gunpowder. A magazine, barracks, and shops were erected on the old militia training field on the hill above the town, in an area now embracing the Springfield Armory's current location.

Beginning in 1778, parts provided by various gunsmiths under Committee of Defense contracts were sent to Springfield for assembly and proof. The first United States muskets assembled there were composed of contract-made parts resembling components of the iron-mounted French musket that had been adopted by Congress as a standard pattern. Once issued, these arms had a tendency to go home with whoever had possession of them. In order to halt or reduce what amounted to embezzlement of Public Arms, Congress had passed an Act on February 24, 1777 that required *UNITED STATES* be stamped or marked on all Continental arms. This marking was often abbreviated to *U. STATES*, or simply *U.S.*

After Yorktown, the fighting ceased, but Congress was burdened with a very large stockpile of captured arms as well as those purchased during the course of the war. Their disposition became a problem Congress resolved in 1782 with the establishment of storage magazines not only at Springfield, but also at West Point, NY; Yellow Springs, PA; and New London, VA. Another facility was soon added on the Schuylkill River west of Philadelphia. At these facilities,

armorers were employed to refurbish and repair the many stored arms.

In the post-Revolutionary War years, the political pot seemed to boil over with various alarms and excursions that necessitated being dealt with by armed troops including Shay's Rebellion (1786-7), Indian troubles in the N.W. Territory (1785-91), and the Pennsylvania Whiskey Rebellion (1794). Refurbished arms from the storage facilities seemed to suffice to cope with these localized problems.

As far as arms were concerned, a make-do attitude was symptomatic of an almost paranoid fear that a strong standing army might be used to subvert hard-won republican goals, creating a political atmosphere in which the regular army's strength was reduced to a near-vanishing point. As a panacea to the inescapable problem of providing for national defense, the burden of maintaining a military posture was laid on the militia of the several States. As the army was being reorganized in the 1790's, the militia too, referred to as the "Bulwark of Our National Defense," stood in need of shoring up. This was initiated by passage of The Militia Act of May 8, 1792, which provided that all citizens arm and equip themselves at their own expense, and that an annual Return be made to the President, reporting the military strength and arms situation of each state. Reporting was desultory.

In December 1793, Secretary of War Henry Knox submitted a Return to Congress of the ordnance, arms, and military stores then in federal arsenals and magazines. The report listed an aggregate of 31,015 serviceable muskets, and 805 useable pistols. In addition, the number of damaged muskets and pistols being stored amounted to more than half of these figures. The hard reality of this report indicated that, unless action was taken to correct the arms status, less than a third of the 100,000-man "Nation's Bulwark" could be issued a weapon in time of national crisis.

Recognizing this, the President sponsored an Armory Bill passed by Congress on April 2, 1794, authorizing the establishment of three or four arsenals, and at each of these arsenals "a national armory" was to be included and tasked with the *manufacture* of arms. Because of its role in the Revolutionary War, President Washington personally selected Springfield as a location for one of these arsenals. The powder laboratory and magazine that the government had owned and operated at Springfield since 1777 was upgraded to what would become the "parent" arsenal. Although new arsenals at Philadelphia and Harper's Ferry were intended to service the middle and southern states, under Secretary of War Timothy Pickering (1745-1829), their development was not given the same priority that Springfield received. Pickering, a native of Massachusetts, believed that Springfield's capacity to fulfill the nation's arms needs would suffice if augmented by the efforts of private contractors.

There is no question but that Washington's establishment of a national armory at Springfield provided a solid cornerstone to the region's reputation as a center for arms making. The year 1795 marked the armory's first year of production, but the armory was slow in coming up to a level of production that would eventually meet the nation's needs. That year of Springfield's initial production, it was only able to turn out about 250 finished muskets. Despite the fact that a second national armory was soon established at Harpers Ferry, West Virginia, a cadre of private contractors were still needed to fulfill our early arms requirements.

Under the threat of renewed hostilities [Quasi-War with France, 1798-1801], an Act passed in May 1798 authorized the raising of a 10,000-man Provisional Army and appropriated \$200,000 so that President Adams might more rapidly acquire arms for the nation. Other provisions of the act authorized the loan to the militia of muskets, accoutrements, and artillery already stockpiled in U.S. Arsenals. However, expansion of the Army outraced the capacity of government arsenals to rapidly produce such a large quantity of arms. The solution lay with the potential of the private sector to add to the nation's stockpile of arms from many small sources.

Private contractors were prone to taking many steps to reduce the cost of making or assembling arms, including the use of discards from the armories. So blatant was the illegal trade in armory rejects that, in the summer of 1799, David Ames, first Superintendent of the Springfield Armory, issued a public notice prohibiting clandestine removal of arms, tools, or materials from the armory. To insure that Public Property arms were recognizable, Ames identified their method of marking in the following manner:

*The barrels are marked on the left side with the letters V. P. and an eagle's head between them, and on the top of the barrel U.S. and the initials of the maker's name commonly on the **underside**.—The Locks are stamped with the **arms of the United States**, and the letters U.S. under the pan, and **Springfield** in a circular form on the bind part of the lock, and the initials of the maker's name on the **inside**. The Bayonets are marked U.S. on the socket, and initials of the maker's name on the **blade**. (Federal Spy—Springfield, August 13, 1799)*

The slowness of production at the national armories dictated that contracts needed to be let out to individuals who could provide assurance that they were capable of manufacturing arms of a quality and pattern that would meet federal and state requirements. This led to the evolution of the "contract system" whereby legally binding agreements for the manufacture and purchase of arms were signed between state or federal government and private arms makers.

In order to permanently provide for arming and strengthening the militia, two more Militia Acts were passed

in April 1808. Under the first act, Congress authorized the sale of private contract-made arms to the states, and by the other act, provided \$200,000 annually for arming the militia. Each state was allocated funding for a given number of muskets each year, based on its population. However, the total number of muskets available for allocation depended upon congressional funding. By implementing the contract system, muskets fabricated at the national armories could be reserved for issue to the regular army. Pursuant to these acts, contract arms purchased by the central government could be transferred to the states for internal distribution as prescribed by each state's chief executive. The disclosure of information pertaining to public contracts under which the arms were procured was made mandatory under legislation enacted at about the same time, thus insuring that such annual statements made by the Secretary of War would reflect quantity, cost, and the identity of arms manufacturers (for which we arms collectors are truly thankful).

In 1808 arms production was still insufficient, prompting the Government to advertise for contractors to furnish muskets of the "French" pattern as made at Springfield and Harpers Ferry. Some of the contracts were given to individuals and some to partnerships with all parties being involved in the manufacturing process. However, some partnerships consisted of financial backers coupled with smiths who actually made the arms. Nineteen contractors were thus awarded 1808 contracts: five were from Massachusetts—one was from the Pioneer Valley—Asher and Pliney Bartlett of Springfield. The Bartlett story is a strange one and worth noting here.

ASHER & PLINEY BARTLETT

Father: Ebenezer Bartlett, Jr. (1745-1788) of Granby, Hampshire Co., MA
Mother: Betty Barbour
Sons: Asher-b. 1771-d. Oct 9, 1816
Pliney-b. Sept 27, 1776-d. Dec 9, 1816

On August 13, 1799, the brothers Asher and Pliney Bartlett advertised in the Springfield *Federal Spy* that they would give "good encouragement" to a "JOURNEYMAN BLACKSMITH who is a proficient in the line of his business." This ad appears to have heralded their entry into the Valley's nascent industrial community. Their next *Spy* advertisement (Nov. 20, 1804) informed the public of the establishment and nature of their work:

... a Gun making business at their shop one mile south of the Meeting-house, where they have constantly on hand and for sale, MILITARY GUNS, made in exact imitation of the French Charleville guns. They also make Fowling Pieces of various price ... N.B. The above described guns are not made of broken barrels brazed together; neither are they

refuse barrels which were burnt in the United States' Factory; but are new and sound, and have been proved with the same quantity of powder and lead which the barrels made for the U.S. Factory are proved.

The reference to broken barrels brazed together and burnt refuse barrels was probably aimed at competitor David Ames (1760–1847), who also engaged in the sale of arms upon his return to civilian life on October 31, 1802, after having been replaced as Springfield National Armory's superintendent. A year later we find him selling arms as per his advertisement in the *Federal Spy* (October 11, 1803) “. . . at his workshop and store, a constant and valuable assortment of Military Pieces—their weight, size bore, shape of the mountings, &c, are like those made for the service of the United States. The above guns warranted to stand a reasonable proof by powder.” In order to make such an offer, Ames probably relied on being able to purchase Armory “refuse” or rejected barrels, locks, etc., so scorned by the Bartletts.

In 1803, President Jefferson appointed Tench Coxe (1755–1824) Purveyor of Public Supplies, a position he held until superseded in July 1812. In this position, Coxe acted as the chief procurer of small arms and military stores for the Army. Acting with the approval of the Secretary of War on an almost contract-by-contract basis, Coxe ordained pattern, quantity, cost, and delivery schedules. His influence in making decisions relating to dealings with the contractors was often decisive.

On Oct. 3, 1808, Coxe informed the Secretary of War that “A. & P. Bartlett, Springfield, Mass. say they are experienced gun smiths, & refer to Mr. Byers conference with you & wish 2,500 stands. Decision postponed for your instructions & for enquiry, but say 2,500.” Apparently Coxe received the assurance needed that they were bona fide arms makers and therefore capable of fulfilling such a contract for, on Nov. 10, 1808, Coxe informed the Secretary of War that in addition to having let out other contracts, A. & P. Bartlett of Springfield, MA, had been awarded a contract to produce 500 muskets yearly for a total of 2,500 over a five-year period.

However, two years later *A Statement of the Contracts Made by Tench Coxe in Consequence of the Public Advertisements of 1808 for Muskets Under the Law of That Year* reflected that up to that date (Feb. 21, 1810), the Bartletts had failed to deliver any arms under their contract. Of eighteen firms that had received contracts, nine others had also failed to deliver by the beginning of 1810. It was time for some nudging on the part of the Government. On March 28, 1812 (2 Sat. 696) an Act of Congress established a Commissary General of Purchases, who would henceforth be responsible for procuring “all arms, military stores, clothing, and articles of supply” for the Army. Effective July 29,

1812, Tench Coxe's role as Purveyor of Public Supplies would be superseded by Commissary General, Callender Irvine (1774–1841). Upon review of the records of the former Purveyor's office, Irvine found much to criticize in the way Coxe had handled the arms contracts, particularly in the Bartlett case . . . much to their sorrow.

Prior to Irvine's intervention, Asher had also contracted with the Commonwealth of Massachusetts (Oct. 31, 1808) to provide 2,500 muskets of 1808 pattern, of which 2,025 were inspected (probably by James Bliss, the Commonwealth's prover of firearms for Hampden County) and delivered by April 1812 (Moller, *Massachusetts Military Shoulder Arms 1784–1877*). Later that year, the Bartletts placed the following advertisement in the *Hampden Federalist* (Sept. 3rd and 10th, 1812):

WAR

The subscribers inform their friends and the public, that they continue to manufacture MILITARY GUNS at their Factory, one mile south of the Meetinghouse, where they keep constantly on hand, and for sale, Muskets, by the chest, doz., or single, of the first quality. They also have muskets less valuable. They calculate to accommodate all those who may call.

— A. & P. BARTLETT.

Springfield, Aug. 1812.

On December 3rd, 1812, the following ad also appeared in the *Hampden Federalist*:

SALES BY AUCTION.

Springfield, (Mass.)

30th Nov. 1812.

The following articles of public property will be sold at Auction at the United States Arsenal at this place, on the 14th day of December next, at 11 o'clock, A.M.

9 tons	SCRAP IRON
1000 lbs.	SCRAP STEEL
5 cwt.	Refuse LOCK WORK & GUN MOUNTING
300	Refuse GUN BARRELS
400	do. BAYONETS
200	do. RAMRODS
5000	do. GUN STOCKS
13	do. GRINDSTONES

JOHN CHAFFEE,

Paymaster & Military Storekeeper

Below and on the same page of the *Federalist*, A.&P. Bartlett advertised that they wanted to hire “one or two lock-filers that are good workmen,” who would be met with “good encouragement.” It could be construed that the Bartletts were gearing up to acquire the Armory's castoffs in order to help catch up on contracts in arrears. Additionally, from 1813 to 1815, gun-maker John Joseph Henry of

Philadelphia used the Bartletts and several other private contractors to supply a total of 4,936 muskets to the State of Maryland. Under these transactions, Henry purchased 917 of these muskets from Asher & Pliney Bartlett (Moller, *American Military Shoulder Arms*, vol. II). This coincidence might cause one to reflect that Asher and Pliney had used their federal advance startup money to finance their state arms deliveries and, in so doing, overextended themselves.

However hard they tried, the Bartletts seemed unable to meet all their arms commitments. In a letter dated Jan. 22, 1814, Irvine informed Secretary of War, General John Armstrong, that "*The petition of Asher & Pliney Bartlett Gunsmiths, is received and has been considered. Permit me to make the following remarks thereon. Their request to be permitted to retain as their own property, the amount advanced them, more than five years ago, is entirely inadmissible . . .*" Among the number of reasons Irvine listed that they be declared in default of the contract included the risk that all other defaulting contractors might also claim the same indulgence, and interest on the money advanced to them should have covered their claim for increased per/unit costs that had occurred over the preceding five years (the advance, of course, had been used, not invested). Having delivered only 1,700 stands of arms, they forfeited the penalty of the bond they had been required to post in order to gain the contract (Schmidt).

The default of the surety bond was a catastrophe that must have weighed heavily on Asher's mind and caused him much mental anguish. A point for further research will be to determine who the bondholders were and what leverage they might have applied in gaining restitution from the defaulting Bartletts. Ultimately Asher cracked under the strain, as was made public in the *Federalist* on Oct. 10th, 1816:

We have received the melancholy tidings of the death of Mr. Asher Bartlett, of this town, and now publish the particulars as given in the Boston Gazette of Monday last.

"Yesterday the body of Mr. Asher Bartlett, of Springfield, Mass. was picked up, while floating near the ship Independence, off Long-wharf, & brought on shore; an inquest being immediately called, the Jury finding no marks of violence thereon, brought in a verdict of accidental death. The body was then removed by some of his friends for respectful burial. It since appears, that the deceased for a few days past had discovered melancholy symptoms of insanity; that on Saturday last he plunged into the water from Chelsea bridge; but the tide being low, he was rescued by some persons who witnessed the rash action, and carried to the hospital, near the bridge, where he recovered, and was placed under the charge of two persons. The watchers, finding him composed, fell asleep; but the maniac perceiv-

ing himself unobserved, escaped, leaving his cloaths, and again plunged into the water and was drowned. We understand he was a person of considerable property, much respected, and has left a family to lament his untimely end."

Having to make restitution of money defaulted under the 1808 contract, and facing a bleak future of being eliminated from further government contracts, it is understandable that Asher took such a drastic means to resolve his dilemma. On Nov. 7th an ad posted in the *Federalist* gave notice that Ezra Osborne, Jr. had been appointed Administrator of Asher's estate and that all claims and payment of debts should be addressed to him. Strangely, three months later, Pliny's obituary appeared in the *Federalist*, but with only a brief notice this time, that he had died on December 9th, and on the 26th a notice appeared naming Benjamin Day as administrator of Pliny's estate. Either Osborne or Day, or both, might have been bondholders.

This final note appeared on January 30th 1817:

PUBLIC AUCTION

Will be sold at public auction to the highest bidder, on Wednesday the nineteenth day of February, next, at 10 o'clock in the forenoon, part of the personal estate of ASHER & PLINY BARTLETT, late of Springfield, deceased; comprising a great variety of articles, among which are the following: —Blacksmith's Bellows—Anvils—Vices—Tongs—Hammers—Files, &c. &c— Also a large quantity of scrap Iron and scrap Steel—Stocking Tools—Bayonets—Ramrods—unfinished Guns—Lock-work—and Stocks. The above articles will be sold in lots as shall best accommodate the purchasers.

The Sale to be at the late dwelling of A. & P. Bartlett.

Ezra Osborne, Jr.

Benjamin Day Administrators

Springfield, Jan. 27, 1817

Some confusion has arisen regarding an Asher Bartlett (hereafter Asher II) who was later employed at Chicopee and Springfield. This was not Asher's son nor Pliney's brother, but another related member of the Bartlett family, probably a nephew or cousin. His origins and work history are as follows:

Born: Granby, Massachusetts, 1817

Father: Waitt Bartlett (1786-1869) of Granby, arrived at Chicopee Falls in 1830.

Mother: Martha G. Chapin

Asher [II], a widower (wife Ellen) at the time of his death, was listed in Skiff's *Almanac, Directory & Business Advertiser for 1845* as a stocker at the Chicopee Falls Village gun shop and still working there until 1849. From 1851 to 1853, he was employed in making belt model revolvers at the Massachusetts Arms Company under various contractual shop agreements. He also worked at Smith & Wesson in 1869 and 1877. From 1870-1876, and 1879-1883, he was employed at

Springfield Armory and was still to be found there from 1886 until 1899, probably in a non-arduous capacity.

CYRUS B. ALLEN

The U.S. military establishment conservatively waited until 1841 to adopt the percussion system, but private sector gun makers in the Pioneer Valley led the decade's most noteworthy efforts to develop repeating or revolving sporting arms based on the more adaptable percussion system. Among these innovators, we find partners Rufus Nichols and Edward Childs (b. 1813) of Conway, Benjamin Franklin Smith (1809-1844) of South Hadley, James Warner (1817-1869), Elijah Fisher, and Cyrus Allen of Springfield. (Sellers & Smith) However, it was Cyrus B. Allen who established a reputation during the mid-1830s for being able to translate various patented repeating concepts into the reality of an intricate firearm mechanism. Allen's production of these marvels was low, in most instances limited to only a few hundred examples, but their high quality was undisputed. Thus far, the following is what I have been able to gather concerning Allen.

Cyrus Bullard Allen was born on January 31, 1807 in Shrewsbury, Massachusetts. He was listed in the *Massachusetts Vital Records* as a child "on record" of Capt. Silas Allen, Jr. (1785-1868) of Sutton and his wife Elizabeth (Betsy) Lamb (b. March 14, 1790) of Spencer, Massachusetts. Silas and Betsy posted their marriage intentions on September 18, 1806, and were married on October 29, 1806. By Massachusetts law, town clerks were required to post notices of intentions to wed in a prominent place for at least three weeks prior to a wedding, or have the bans read aloud from the church pulpit. In order to downplay gossip, bans were sometimes unobtrusively posted in a town other than the one in which the couple would be married so that the ceremony could occur quietly without further publicity. In Cyrus' case, being born three months after his parents were wed was not so unusual for the time, but Silas and Betsy probably chose this means to reduce gossip regarding their premarital relationship.

Cyrus had two brothers, Arnold Lamb Allen, b. March 25, 1808, and Simon Hapgood Allen, b. November 8, 1811. The Allens and Hapgoods were related by marriage. Silas' sister Elizabeth Cunningham Allen wed Ephriam Hapgood, brother of the father of gunsmith Joab Hapgood (1804-1890). Cyrus' family also had a close relationship with his first cousin Asa Henry Allen (son of his uncle, Noah Allen). Asa named three of his children after members of Cyrus' immediate family—a daughter after Cyrus's mother, Elizabeth Lamb—a son named after Cyrus, born March 14, 1841—and another son named after Simon, born Dec. 16, 1842. (Hutchinson) By 1820, Silas Allen, Jr. had established a

successful arms business with several apprentices and journeymen in his employ. Among those relatives who served apprenticeships in the Allen shop were Cyrus, his son-in-law's nephew Joab Hapgood, and Joab's younger brother David. T. Hapgood. Silas finally retired from gun making in 1845 and turned his remaining energy to farming.

While C.B. Allen does not appear in Springfield in the 1830 or 1840 Massachusetts Census Index, this omission is explained by the fact that probably Allen arrived in Springfield too late to be enumerated in 1830 and departed too early to be counted in 1840. However, an entry in the Hampden County Registry of Deeds (book 100, p. 188) recorded that "*Cyrus B. Allen, gunsmith, late of the firm of Allen & Barber*" had purchased a plot of land on April 4, 1835. This is the earliest notice that Allen was already a Springfield resident and that he was involved in making firearms. Allen's first partner, John D. Barber, was still listed in the 1853 Springfield city directory as a gunsmith.

It was in September of 1834, however, that Allen and Charles Ball announced their partnership in both the *Hampden Whig* (filed Sept. 9, 1834) and the *Springfield Republican* (Sept. 20, 1834). The advertisement informed the public that they "*would continue to manufacture (at the shop in Maple street) GUNS of every description. Also, machinery of all kinds, particularly where great accuracy and excellence of workmanship are required.*" An added note indicated that they would accept wood (probably for gun stocking) and most kinds of produce in exchange for their work. Their ad also stated a desire to hire an apprentice, "*one who has manifested a decided aptitude for mechanics . . .*" A young toolmaker from Chester, Massachusetts, by the name of Joshua Stevens (1814-1907), was hired about that time.

On March 11, 1835, Allen & Ball announced in the *Republican* that they "*had removed into their new shop, near the old one in Maple Street.*" The shop's new location appeared on George Colton's 1835 *Plan of Springfield*, at what was the northwest corner of Central and Chestnut (Fig. 1). It was a fortunate location enjoying water power privileges derived from Rumhill's Pond located across Maple and uphill from the shop. The tool-making firm of Winship & Hills was conveniently located almost opposite them. Once in their new location Allen & Ball placed ads in the *Hampton Whig* (March 11, 1835) to the effect that:

. . . they keep constantly on hand a supply of rifles and fowling pieces, warranted to be equal in workmanship, and for accurate shooting, to any in the United States. Gun locks made to order both for flint and percussion—flint locks altered to percussion, and repairs of all kinds done in the best manner. Old rifles made into shotguns and warranted to shoot well—First quality powder and percussion



Figure 1. Detail, *Plan of Springfield*, published by George Colton, 1835. The shop of Allen & Ball is located at the northwest corner of Chesnut and Central Streets. [Courtesy of the Connecticut Valley Historical Museum]

caps—black walnut gunstocks, and parts of guns for sale. Machinery they promise to make with despatch [sic.], neatness and greatest accuracy. Patterns for castings made to order and warranted to mould. Tools of all kinds, for fine work or course [sic.], finished in the best style if desired, and warranted to work well.

This advertisement was much more descriptive of the work they turned out than ads placed the previous September and are indicative of expanded business opportunities. In the same issue of the *Hampden Whig* (March 11, 1835) the paper's editor reported on what he termed a novel "Cylinder Cannon" that his two new "enterprising and ingenious" advertisers were making. This "Cylinder or Rotary" cannon was the brainchild of John Webster Cochran (1811-1873) of Lowell, MA, for which its inventor was issued a U.S. Patent on October 22, 1834 (Fig. 2)—a year and four months **before** Sam Colt had received his first revolver patent on February 25, 1836. The editor was given a briefing and live-fire demonstration and had this to say:

This Cannon is constructed with a Cylinder, on the surface of which are two tiers of holes, twelve in each tier. In these the charges are deposited. The Cylinder is placed on a solid platform and is turned with a crank. The barrels, two in

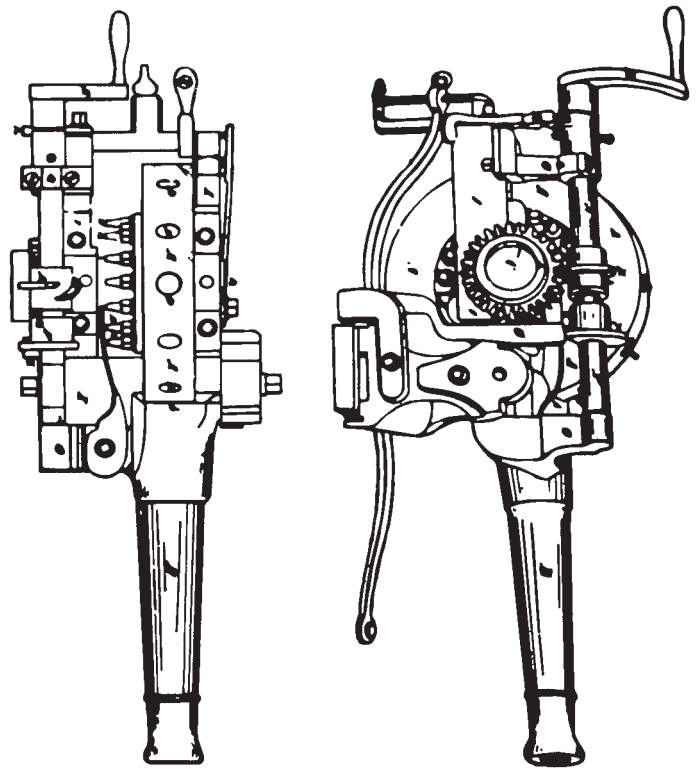

Figure 2. Patent drawing of John Webster Cochran's "rotary cannon" (U.S. unnumbered patent issued October 22, 1834). Allen made the mechanisms and N.P. Ames cast the bronze barrels. Cochran's rotary cannon is considered one of the earliest of Allen's special projects.

number, to correspond with the tiers of holes, are so placed as to being them in direct contact with these holes as the Cylinder revolves. In the end of the Cylinder are other holes, communicating with those on its surface. In these are placed cones for the reception of the caps—The caps are contained in a charger, and from it, are deposited upon the cones by the operation of a Cam. When so deposited, the holes on the surface of the Cylinder are in contact with the barrels, and at this instant a spring, on the principle of the percussion lock; strikes a cap, igniting the powder and discharging the cannon. The whole machinery is simple, but perfect in itself, and the whole operation of it, save depositing the charges, performed by turning the crank. The one shown us had two barrels, and on trial, was made to discharge twenty four guns in the space of six seconds. Any number of barrels may be added by increasing the length of the Cylinder, without adding to the complication of the machinery. The Cannon was built by Messrs. Allen & Ball for a company in Lowell. The company we understand, have procured it to be patented in this country and France, and have now an agent in England for the purpose of getting it patented there. It was to us, altogether a novel piece of machinery, and the idea of a cannon being fired, gun after gun, by an operation like that of a boy turning a grind stone struck us as strangely singular. It exhibits however, a degree of skill & ingenuity in these mechanics which deserves to be encouraged by the public.

The machinery aspect of their business is glimpsed in a brief reference to be found in Nathan P. Ames' *Memorandum Book No. 7* (pg. 59), wherein on February 25, 1835, the following account of Allen & Ball is credited:

<i>For finishing 50 set small gears</i>	
<i>@ 4/6</i>	<i>37.50</i>
<i>For finishing 6 fricktion [sic] rolls</i>	
<i>March 20</i>	<i>3.00</i>
<i>For Lathe screw and nut</i>	
	<i>2.50</i>

The exacting machine work done for Ames must have been satisfactory, because on July 20th, 1835, Nathan Ames wrote from Philadelphia to his brother James that:

The bearer of this is Mr. Elgin, the patentee of the combined Bowie knife & pistol. He visits Springfield to ascertain whether arrangements can be made on manufacturing them ... Shall leave it to you to decide if we can do anything for him ... advised him to call Allen & Ball ... Hope you will give assistance.

This letter of introduction resulted in Allen & Ball producing George Elgin's 1837 patent combination Pistol Knife or Cutlass, thus setting in motion the manufacture of another unique Allen firearm (Fig. 3). In collaboration with Ames, the

blades were attached under the barrel by a tongue and groove method secured by two screws.

Throughout the months of June and July of 1836, Allen & Ball also advertised in the *Hampden Whig* for additional workmen, particularly for one forger and three filers. One of the workmen answering the advertisement was machinist Ira Leonard of Lowell. As a witness in the Colt vs. Mass Arms Co. patent trial, Leonard stated that in 1836 he had "worked on Cochran's rotating guns a short time, between two and three months" prior to working for Sam Colt in Paterson, New Jersey. (Rywell) Another craftsman employed by Allen at this time was the engraver Richard Bates Inshaw, Sr. (1805-1865). This fact is supported by a letter from N.P. Ames to his brother James, dated July 18, 1836, regarding a presentation sword to be made for the State of New York to present to Lt. Daniel Turner. In this letter N.P. wrote "Inshaw the engraver is not to be found in the city and has not been at the place where he worked for several days. I think it would be well to see Allen & Ball and make arrangements to secure him if possible as we shall unquestionably want his work." This note implies that Inshaw was employed by Allen and was probably responsible for decorative engraving found on Cochran "turret" rifles and pistols.

On July 29, 1836, Allen and Ball signed papers dissolving their partnership by mutual consent. What brought this about is not yet known. On August 3rd, Allen bought out Ball's title to the piece of property the shop was on and his interest in the "rifle shop" for the sum of \$1,500. As reported in the *Hampden Whig* (Aug. 10, 1836), the business had been transferred to Allen, who was authorized to settle and discharge all previous notes and accounts. A notice of the dissolution of their partnership also appeared in the *Springfield Gazette* (Aug. 13, 1836). Assisted by a small work force, Allen became renown for making percussion firearms for inventors of unusual multi-shot designs. His high-quality production never amounted to more than a few hundred examples of each design, but altogether his work represented some of the most mechanically ingenious multi-shot arms of the early American machine tool era. However, in the spring of 1837 disaster struck Allen as reported in the *Springfield Republican & Journal* (March 18, 1837):

Fresbet—In consequence of the rain and melting snow on Monday last, we had something of a fresbet, which occasioned considerable damage. The small streams were much swollen, and the meadows east of Main Street, above Court Square, were for the most part completely overflowed so as to resemble a large pond. The small brook running from the dingle east of Maple Street, commonly known as "Martha's Dingle," was so much swollen by the water flowing into it that it tore away with great violence, the dam connected with Hills & Winship's Tool Manufactory, and rushing

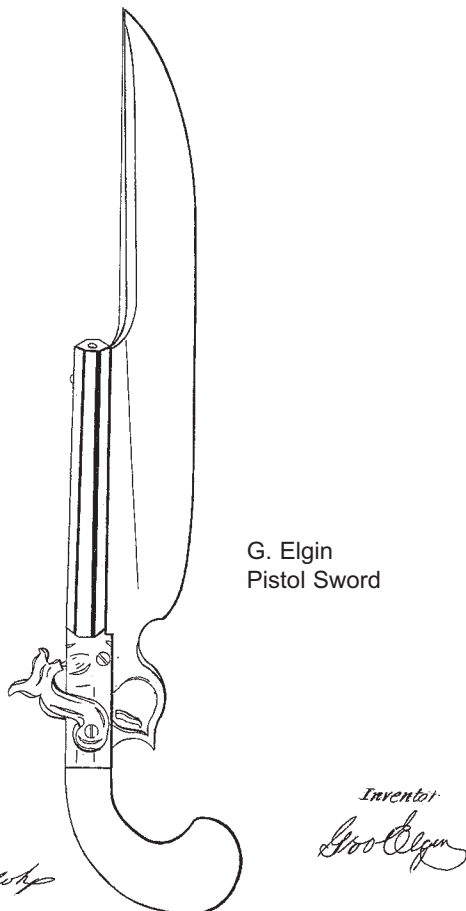

Figure 3. Patent drawing of George Elgin's bowie-knife cutlass pistol (U.S. Pat. # 254 issued July 5, 1837). Allen made the pistol and N.P. Ames provided the knife blades.

through the lower part of that shop, passed across Maple Street, making a deep and broad chasm therein. Thence it passed to the Rifle Manufactory of Mr. Allen, the lower or basement story of which it broke through, demolishing for the most part the east and west walls of the same, and flowed into the meadow below, where it found full scope for its impetuosity. The waters carried with them into the meadow a large number of valuable tools of Mr. Allen. His loss of property will not probably be less than \$1,000. The loss of Messrs. Hills & Winslip, in the damage done to their tools as well as to the shop and dam, cannot it is supposed, fall much short of \$2,000. Both establishments will also suffer much from interruption and derangement in their business.

However much damage the fluke of nature flood caused, Allen appeared to have rapidly recovered from it. Three months after the deluge, he placed an ad in the *Republican* (June 10th) for the sale of “Cochran’s Patent many chambered Rifles and Pistols,” also noting “he has been the exclusive manufacturer of the article.” This was based on Cochran’s 1837 patent for a many-chambered-cylinder rifle or pistol (Fig. 4). The extent of the business with Cochran was extensive as we shall see.

A Massachusetts Act, approved on March 8, 1805, provided for the proof of firearms manufactured within the Commonwealth of Massachusetts. This system applied only to military arms suitable for militia service, but excluded barrels intended for use on fowling pieces. This county-based proof system functioned until 1842, at which time Massachusetts reorganized its militia and began to rely on federally supplied arms (Puleo). For the most part, persons commissioned as “Provers of Firearms” were gunsmiths residing in the several counties, allowing for no more than

two in a county, appointed by the Governor. Under this system, James Bliss of Springfield (Hampden County) was one of the first provers to receive a commission in 1805. Later, in 1837, C.B. Allen was also commissioned an official “Prover of Firearms” for the Commonwealth. Since Allen was the only other prover appointed for Hampden County, it is likely that he received his commission as Bliss’s replacement. Fees derived from proving would certainly have helped alleviate losses suffered by the flooding of the shop, but Allen was to suffer further hardship.

In May of 1837 the nation’s banking system began experiencing great distress. Congress had distributed the surplus in the Treasury to the various states, which sparked a reckless spirit of speculation and spending. When the payments were withheld in order to pay the national debt, the states found themselves financially overextended. Local banks had to suspend specie payments and were forced to issue their own greatly discounted notes, which only served to inflate the country with worthless paper money. Private individuals and tradesmen such as Allen found it difficult to do business, and the period was characterized as being one of “Hard Times” for all. In this depressed economic climate, on July 5, 1837, Allen found himself forced to sign a promissory note to Springfield resident Ocran Dickinson in the amount of \$1,000 using his Springfield lot, shop buildings, power privileges, and machinery as collateral. (Hampden County Registry of Deeds).

By October 1837, Allen appeared to have made headway in recovering from the combined effects of the flood and the “hard times.” In response to a new law of the Massachusetts Legislature in 1837, Springfield’s Assessors were required to assemble principal manufacturing statistics that would be published in the *Statistics of Agriculture and Manufacturing of Hampden County*, which was reprinted in the *Springfield Republican* on October 14, 1837. From that report, it was made known that Allen had \$8,000 capital invested in specifically producing Cochran rifles valued at \$18,000 while employing a workforce of 18 “hands.”

Allen’s five-year span of activity in Springfield appears to have commenced with the production of a prototype of Cochran’s revolving-chamber cannon followed by several hundred Cochran revolving

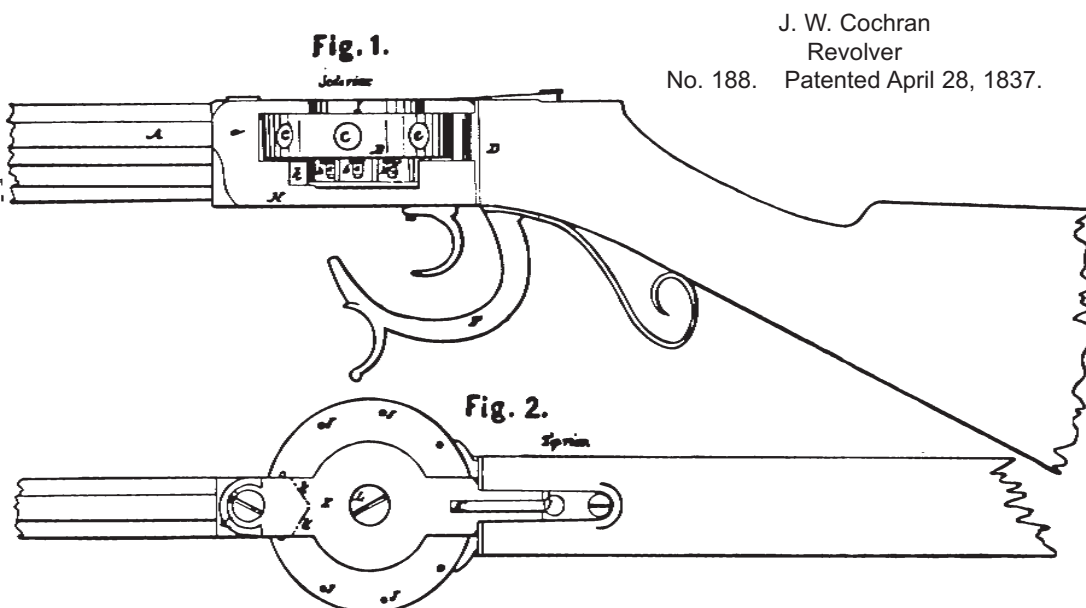

Figure 4. Patent drawing of John Webster Cochran’s revolving “turret” rifle or pistol (U.S. Pat. # 188 issued March 8, 1837). Allen advertised that he had been making Cochran’s arms prior to July 1837.

“turret” rifles and pistols. A contract with the U.S. Navy documents the 150 combination bowie-knife/boarding pistols he made on George Elgin’s patent. Allen also made perhaps 10 single-shot tip-up, breech-loading combination rifle/shotguns utilizing self-contained percussion cartridge chambers based on the 1838 patent of Samuel Adams of Troy, New York (Fig. 5). An exquisite example of this rifle, in the collection of member Dick Littlefield, is marked “C.B. Allen” on its back-action lock plate, and “Samuel Adams Patent/Chicopee Falls Co., MS.” on the barrel.

Of the other Allen-produced arms, it has been estimated that less than 10 “harmonica” style multi-chambered repeating rifles on the 1837 patent of Elijah Fisher and Dexter H. Chamberlain have come to light (Fig. 6); less than five removable charger single-shot rifles on the Henry and Charles Daniels February 1838 patent (Fig. 7); and about 50 of their sealed-chamber “turret” rifles based on their April 1838 patent were produced (Fig. 8)—all made by Allen.

Allen’s story comes to an abrupt close on September 18, 1841. The *Republican* ran an obituary notice that “Mr. Cyrus B. Allen, recently of this town,” had died of smallpox “unmarried” at Philadelphia on August 13th. It has not yet been ascertained if Allen was in Philadelphia seeking a wife or a business opportunity. He was only 34 years old at the time of his death and should have reasonably expected a much longer life. His Springfield affairs appear to have not been entirely settled as we learn from a notice placed in the *Republican* on Sept. 14, 1841, stating “*Silas Allen has been appointed Administrator of Cyrus B. Allen’s estate. All per-*

sons having demands upon the estate of the deceased, or indebted to the same, are called on to make payments to Silas Allen, or present bills for payment at the law offices of Chapman & Ashmun.” Allen had accumulated \$6,000 worth of debts, the largest being \$1,085.69 due the Ames Manufacturing Co. It has been speculated this debt was incurred for Ames-made blades used in the Elgin cutlass pistols that bear Allen’s name. (Paterson)

While the U.S. military waited until the 1840’s to adopt the percussion system to its arms, the civilian sector wholeheartedly adopted the convenience and reliability of percussion cap ignition. Among the more interesting civilian percussion arms that became popular at this point in time was the single-shot under-hammer pocket pistol based on the 1826 patent issued to Fordyce Ruggles of Hardwick. The manufacture of this type of pistol was concentrated in the region between Brimfield and Springfield and its makers included Adin Ruggles (1793-1833), Aaron Davis, Jr., George W. Shaw (1806-1875), A. Thresher, and Robert W. Andrews of Stafford, CT; William T. Clement of Greenfield; Dudley D. Sacket (1805-1858) of Westfield; and Gibbs, Tiffany & Co. of Sturbridge. (Logan)

Eventually, by the end of the 1850’s, the problem of not being able to efficiently seal off chamber gases and the resulting danger of simultaneous multiple discharges combined to convince most arms makers of the impracticality of revolving percussion shoulder arms. However, during the 1850’s the concept of a revolving percussion pistol was hotly pursued by Valley gun makers such as Albert Parker,

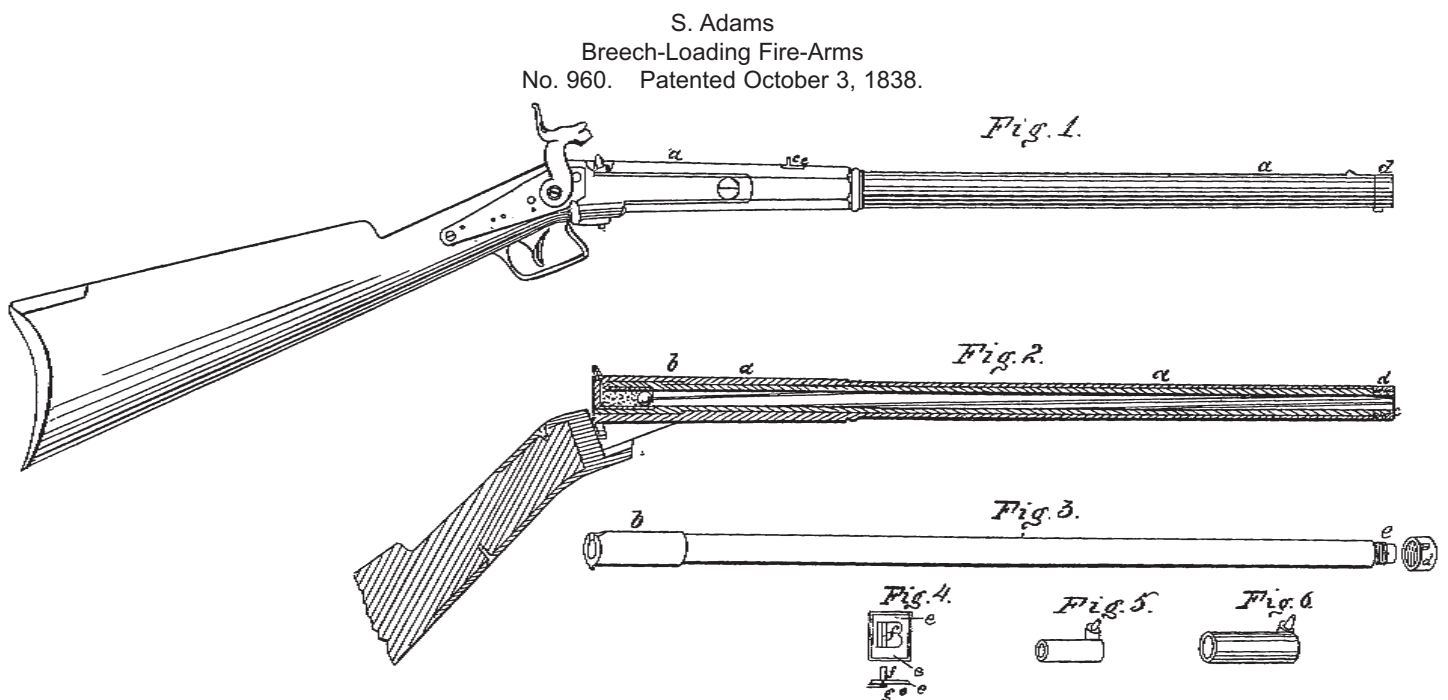

Figure 5. Patent drawing of Samuel Adams’ single-shot combination rifle/shotgun, utilizing a removable rifled barrel liner and steel auxiliary percussion chambers conforming to each mode of use (U.S. Pat. # 960 issued Oct. 3, 1838). The back-action locks were marked “C.B. Allen” and the barrels were engraved “Samuel Adams Patent” in script and stamped “Chicopee Falls Co. Mass.” Adams was a Springfield resident.

Isaac W. Brown, James Warner (a.k.a. Springfield Arms Co.), and the Massachusetts Arms Company of Chicopee Falls. (Sellers & Smith) Samuel Colt of Hartford was just as vigorous in defending his 1836 patent covering the single-action revolving cylinder. In 1851 Colt's infringement suit against the Massachusetts Arms Co. resulted in the most important litigation ever faced by an American arms maker. The court ruled against Massachusetts Arms Co., forcing them to make reparation to Colt, and served to warn off others, such as Warner, from poaching on Colt's revolver patent until it expired in 1857. (Rywell) Both Massachusetts Arms Co. and Warner immediately came up with

several interesting alternative methods of manually revolving the cylinder.

During the late 1850's and throughout the 1860s, a wave of interest blossomed in the self-contained metallic cartridge for which Horace Smith and Daniel B. Wesson obtained proprietary patents in 1854 and 1860. (Jinks) Interest in the variety of mechanical applications afforded by the convenience of an inexpensive .22 caliber rimfire cartridge led to a spate of small single-shot pocket pistols or "deringers" being produced in and around Springfield. Those that went beyond the drawing board phase and into actual production were made by:

- 1857-60 Hosea C. Lombard
- 1858 John B. Driscoll
- 1859 Willard C. Ellis
- 1860-61 Jabez C. Terry
- 1863-69 W.W. Cowles and his partner Gilbert Smith
- 1864 Joshua Stevens
- 1864 James Warner
- 1865 Edwin L. Dickinson and his brother John H. Dickinson
- 1868-70 Lewis B. Taylor
- 1873 Gardner Levi Holt and Joseph Clinton Marshall
- 1874 Louis C. Rodier and his partner Francis G. Bates
- 1876 Charles S. Shattuck and his partner Andrew Hyde

Fisher & Chamberlain
Breech-Loading Fire-Arm
No. 168. Patented April 17, 1837.

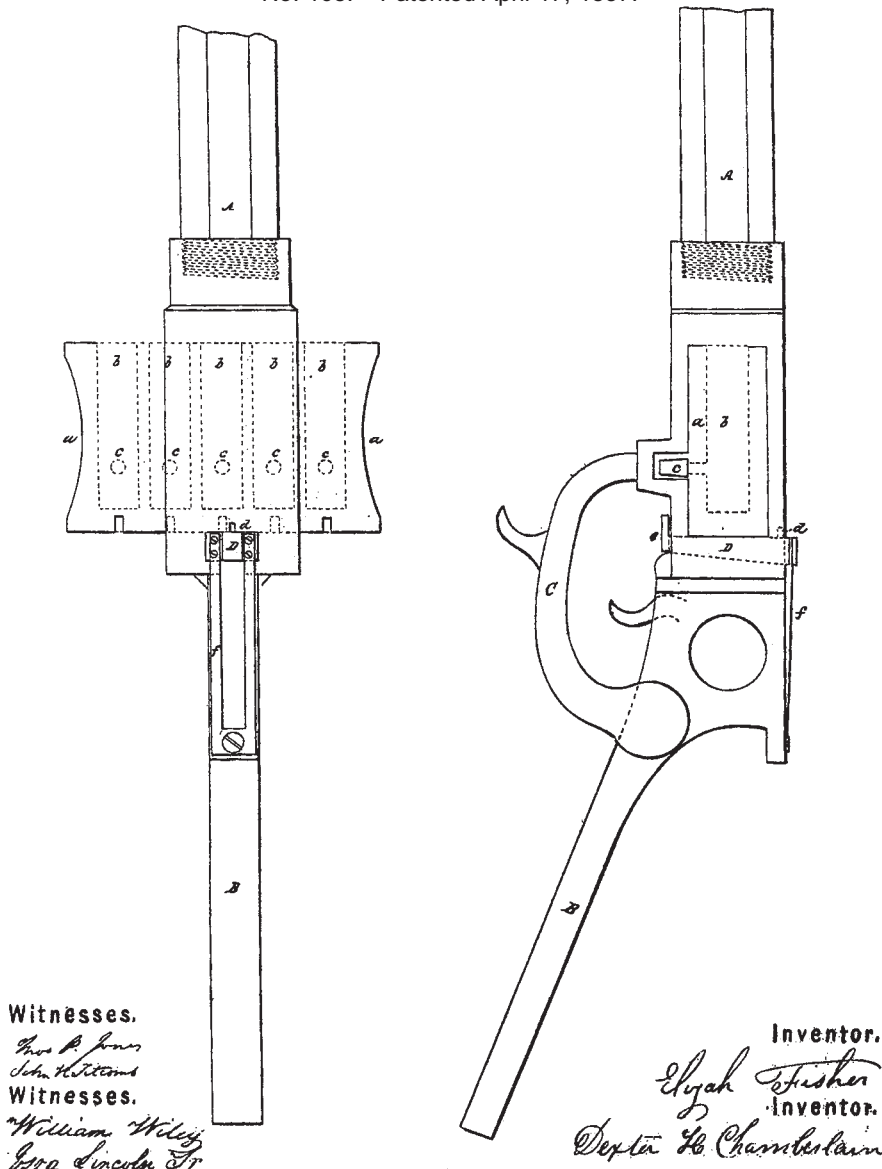

As the clouds of civil war descended upon the Valley, great emphasis began to be placed upon the development of breech-loading arms utilizing self-contained metallic cartridges. A host of different breech mechanisms were patented in fervent hopes by their originators that they might secure a U.S. Government contract, many of which also included the concept of magazine-loaded repeating arms. However, among the single-shot breech-loading cavalry carbines produced by private Springfield and Chicopee contractors were the Warner, Maynard, Green, and Smith carbines.

AMERICAN MACHINE WORKS

One of the three manufacturers of the Smith carbine was the American Machine Works, whose workshops were established near Armory Square in 1847 with a purpose of manufacturing steam engines, saw mills, and

Figure 6. Patent drawing of Elijah Fisher and Dexter H. Chamberlain's "harmonica"-style magazine repeating rifle (U.S. Pat. # 168 issued April 17, 1837). The chamber block slides laterally through a mortise between barrel and breech. A vertically sliding wedge eliminates space between the mouth of a chamber and the breech of the barrel. Elijah Fisher was a Springfield resident.

H. & C. Daniels
Breech-Loading Fire-Arm
No. 610. Patented February 15, 1838.

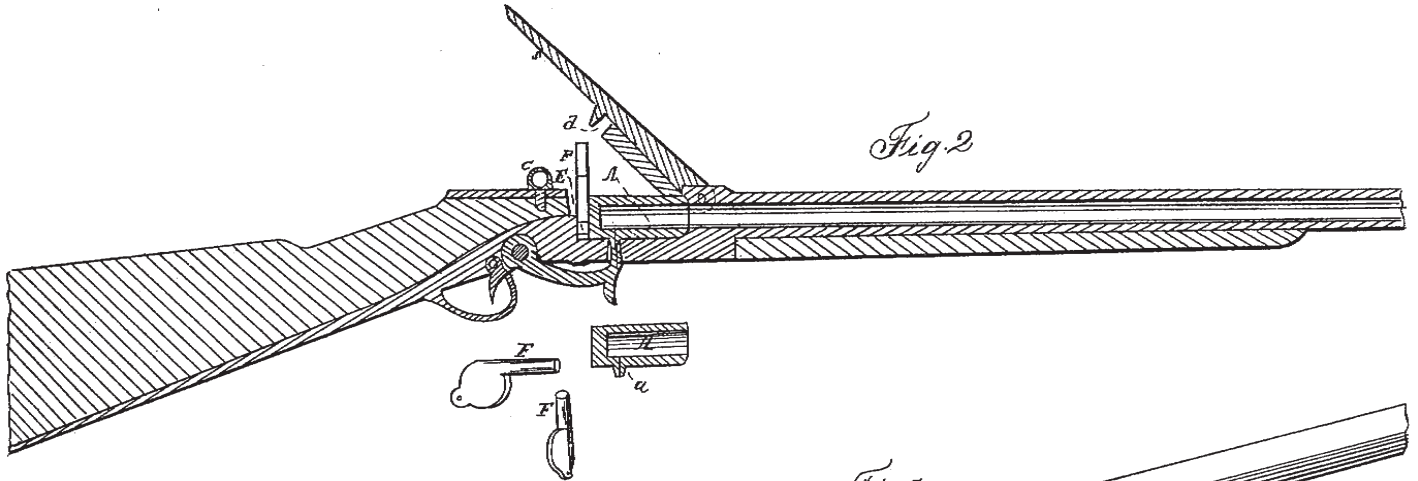

Fig. 2

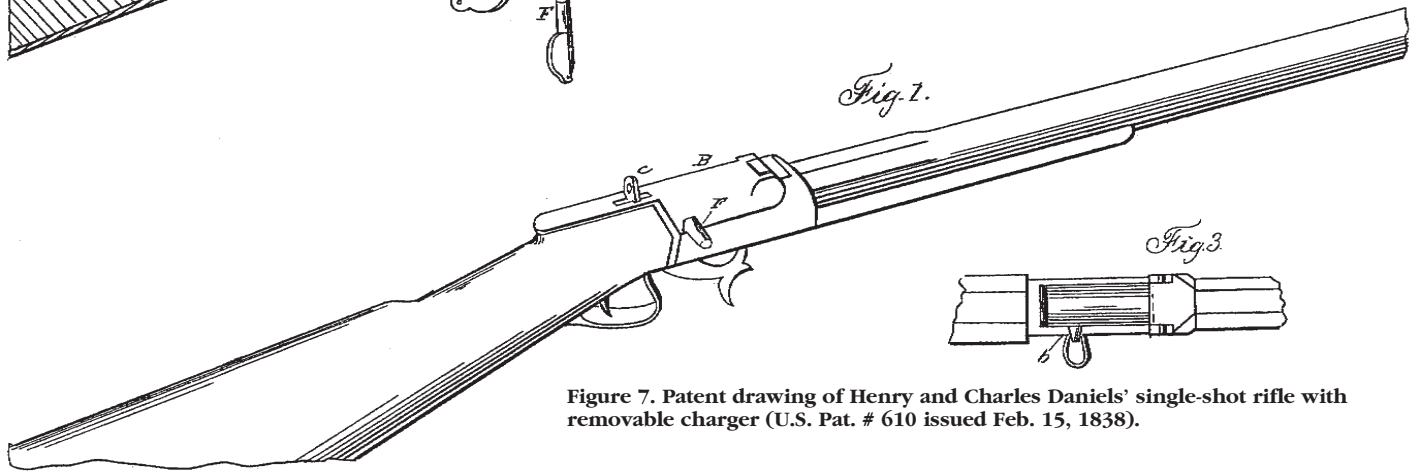

Fig. 7.

Fig. 3

Figure 7. Patent drawing of Henry and Charles Daniels' single-shot rifle with removable charger (U.S. Pat. # 610 issued Feb. 15, 1838).

H. & C. Daniels
Revolver
No. 677. Patented April 5, 1838.

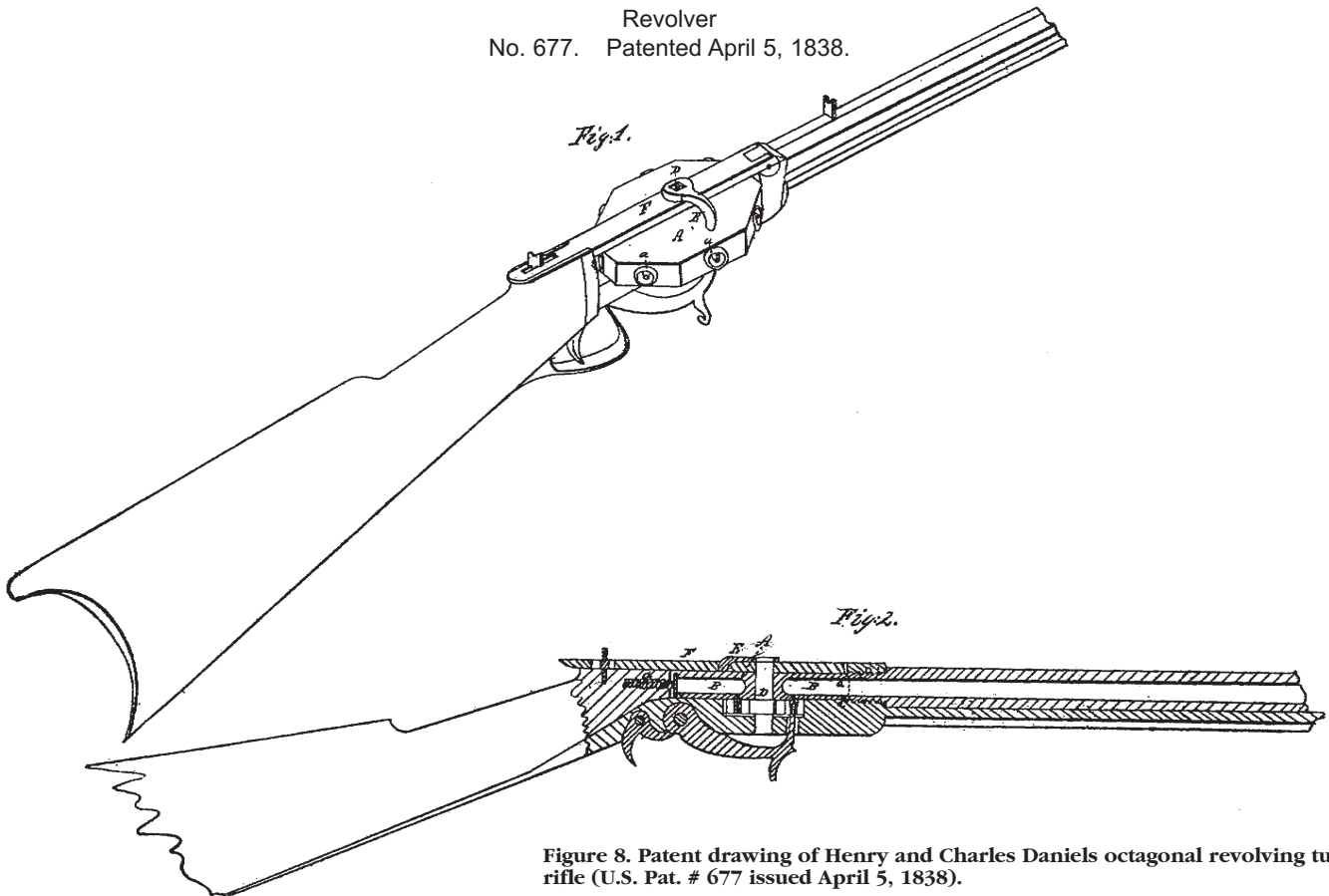

Fig. 1.

Fig. 2.

Figure 8. Patent drawing of Henry and Charles Daniels octagonal revolving turret rifle (U.S. Pat. # 677 issued April 5, 1838).

inventor's prototypes. Philos B. Tyler (b. 1817) was named President and agent of the company. The operation started in a wooden building with \$19,000 capital, which by 1851 had been converted into brick buildings backed by \$40,000 in capital, the firm's rapid success having rested primarily on its production of Tyler's Truss-Frame stationary steam engine.

Soon the company was also producing circular, single, and gang saw mills; shingle machines; portable grist mills; quartz crushing and plaster mills; and superior blowing fans. The shops included a machine room, foundry, forging room, boiler manufactory, and pattern room. Importantly, one room of the new building was set aside for "bringing out the new contrivances of inventors." In this early stage of the company's development, there were about 130 employees. In 1853 Tyler's standing in the community rose as he was nominated as the machine-shop workman's candidate for Mayor of Springfield. On January 9th, 1854, Tyler pulled together a majority of the democratic votes to become Springfield's second Mayor (Fig. 9).

In the summer of 1854, Congress decreed that civilian superintendents would be appointed at Springfield and Harper's ferry national armories. Among the names mentioned for the Springfield appointment was Mayor Tyler's. However, that August, he lost out to master armorer Erskin S. Allin, who was placed in temporary charge.

In 1861 American Machine Works advertisements began to announce that the firm also produced gun-making

machinery, castings, and forgings and that they had already provided \$21,000 worth of stocking and heavy milling machines to C.B. Hoard of Watertown, New York, in order for Hoard to complete his contract with the government for 50,000 Springfield pattern rifled muskets, but it was with considerable jubilation that on October 15, 1863, the *Springfield Daily Republican* reported:

Increased Business Activity

The American Machine Works; P.B. Tyler, superintendent, which have been comparatively idle during the past year and a half, are making preparations for more extensive operations than they have ever carried on before. Some time ago they obtained in connection with the Massachusetts arms company of Chicopee, a contract for manufacturing 5,000 Smith carbines, under the patent owned by Poultney & Brown of Baltimore, and lately they have obtained another of 12,000, all of which latter will be made in this city, as the Massachusetts company will hereafter make only the Maynard rifle. The Smith carbine is now the favorite arm in the cavalry service, and is considered by leading military men as the best for this use now made. Besides the carbine, the American works have obtained a contract from the Plant manufacturing company of New Haven for 10,000 pistols under White & Ellis' patent, with the privilege of increasing the number to 20,000. In order to execute these large contracts the company are enlarging their already extensive works, by the erection of a block 110 by 30 feet on Orleans street, in part of which will be the company's offices. This is now going up with a sufficient force to complete it within three weeks from the time it was commenced. Another block 30 by 60 feet will also be erected immediately at the other end of the works, facing on Swan street. These additions, as well as the rest of the establishment, will be filled with \$20,000 worth of new machinery, and as soon as this is in, 250 workmen will find employment. To give the latter an abiding place, the company have commenced erection of a three-story boarding house 102 by 36 feet on the corner of Quincy and Orleans streets. But this will only partially meet the demand, and the call for tenements and boarding places, which is now greater than can be supplied, will be still further increased.

As American Machine Works became a subcontractor to Massachusetts Arms Co. by manufacturing Smith's cavalry carbine under Gilbert Smith's Pat. # 15,496 issued Aug. 5, 1856, the Massachusetts Arms Co. *Ledger Book* covering the period from October 1849 to April 1868 reflects that production costs for the Smith Carbine began to be recorded in April 1860, and revenues began to be received from Poultney & Trimble shortly thereafter. However, entries for American Machine Works did not appear in the accounts until February 1864, with the last entry dated in October of



Philos B. Tyler.

Figure 9. Philos B. Tyler (1817–c.1890), president and operations manager of the American Machine Works. Tyler served as Springfield's second Mayor in 1854. [King's Handbook of Springfield, 1884]

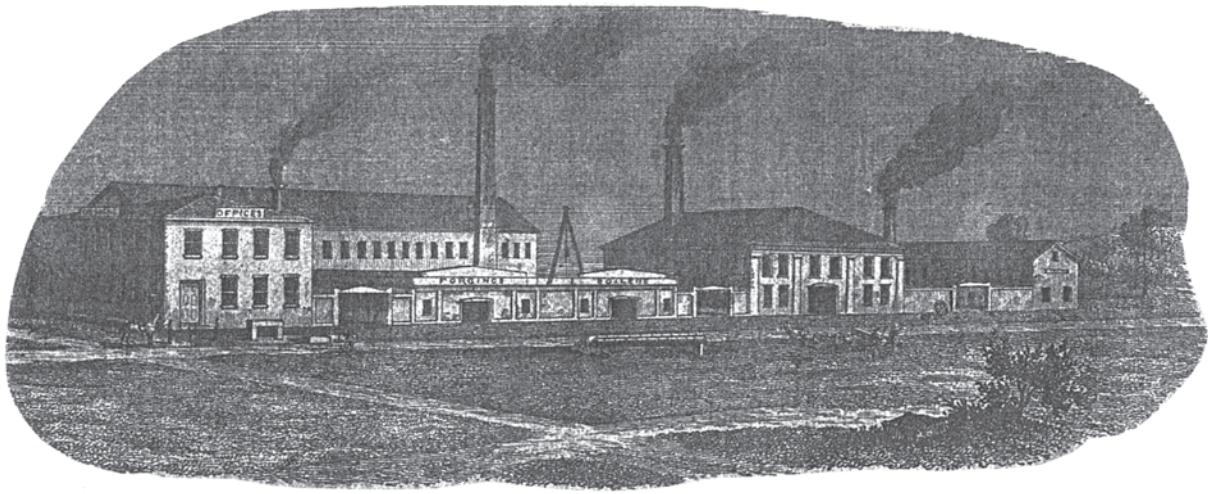

Figure 10. Buildings of the American Machine Works. This vignette of the shop works appeared on the *Map of Springfield Mass.*, as surveyed and drawn by Marcus Smith and H.A. Jones, and lithographed by A. Kollner of Philadelphia in 1851. [Courtesy of the Connecticut Valley Historical Museum]

that year. Thus, it appears that the firm's production of the Smith Carbine was confined to just one year, 1864—but the news that they also made the Plant revolver should come as a bit of a surprise revelation to arms collectors. It is interesting to note that witnesses to the Henry Reynold patent (Pat. # 42,688 of May 10, 1864), covering a latch-bolt style extractor rod for the Plant revolver, were Philos B. Tyler and Ebenezer H. Plant.

Springfield also became a center for the manufacture of percussion caps, tape primers, and cartridges. Charles D. Leet assumed a major role in manufacturing S&W cartridges as well as a variety of large-caliber cartridges for breech-loading rifles and carbines, while James Chattaway specialized in manufacturing his 1856-patented Maynard tape primers and “waterproof” copper percussion caps. Simultaneously, cartridges underwent considerable refinement, making them sturdier and less susceptible to deterioration. Many attempts were made to construct cartridges with different properties that would insure an effective gas seal within the chamber of the firearm, reduce corrosion and deterioration, and be capable of being reloaded. These efforts included attempts to use rubber or bimetallic cases and pulp (*papier mâché*) liners.

After the war, on the commercial level, civilian arms makers resumed their pursuit of the sporting market by developing handguns, shotguns, and hunting and target rifles that utilized the self-contained metallic cartridge. So thorough was acceptance of the metallic cartridge that throughout the last quarter of the nineteenth century many patents were issued to local inventors to cover a variety of cartridge reloading implements such as George Washington Hadley's pocket capper/de-cappers (Pat. # 201,744 of March 26, 1878 and Pat. # 310,583 issued Jan. 13, 1885) for Maynard rifles and made by the Massachusetts Arms Co.

Earlier, Charles A. King of Springfield patented a de-capper (Pat. # 120,075 issued Oct. 17, 1871) that utilized hydraulic pressure to eject primer caps—an example of “thinking outside the box.” Individual sportsmen were thus able to cast bullets of various weights and shapes, remove used primer caps and replace them with fresh ones, and reload empty cartridge cases with a gunpowder and quantity of their choice. This ability to introduce variables to the reloading process spurred the customizing of commercially available cartridges. The marksman was then able to better fit his ammunition to the performance idiosyncrasies of a specific rifle in order to obtain optimum accuracy, performance, and economy. Maynard and Stevens both produced proprietary cartridges in various calibers, which were improved upon (usually Stevens improving upon the earlier Maynard's, as in the notable case of the Maynard .32-35 being supplanted by the Stevens .32-40).

Among the most successful Valley makers of post-civil war sporting breech-loading shoulder arms were the Massachusetts Arms Co., and on the opposite bank of the Chicopee River, the J. Stevens Arms Co. The Massachusetts Arms Co. placed sole reliance on a sporting version of the tip-up carbine patented by Dr. Edward Maynard (1813-1891) that had been the basis of the firm's wartime production. The improved “Maynard” target rifle, as marketed by Massachusetts Arms Co., set a high standard for precision performance with a wide variety of proprietary cartridges whose ballistics were specially designed for target work at ranges up to 1,000 yards. Massachusetts Arms Co. in particular benefited from Hadley's ideas, including his patent for a rack and pinion-adjustable tang peep sight (Pat. # 172,465 issued Jan. 18, 1876) and an adjustable aperture sight disk (Pat. # 362,956 issued May 17, 1887). Long-range competition, spurred by the highly publicized international

Creedmoor and Wimbledon matches of the 1870s, allowed the Maynard to gain a market share along with leading long-range rifle manufacturers such as Sharps and Remington.

By 1890, the Stevens drop-breech rifle began to supplant the Maynard in popularity. The Stevens' success benefited from independent efforts to upgrade the ballistics and accuracy of original Maynard cartridges and being flexible in offering special models adapted for target work according to an offhand (standing) format popularized by German-American marksmen. A new species of American target rifle emerged that included a number of Stevens improvements such as vernier adjustable sights, ergonomically designed stocks and butt plates, a variety of barrel weights catering to differing physiques, double set-trigger assemblies, and palm-held supports. James Herbert Bullard (1842-1914) joined the ranks of Valley sporting rifle makers in 1882 by adding single-shot target rifles to his Springfield-made line of lever-action magazine rifles. At the same time, Henry A. Buck, of West Stafford, Connecticut, produced a lever-action rolling-block single-shot target rifle, which he co-patented with Henry Whiton (Pat. # 214,098 issued April 8, 1879) and manufactured in the Whiton machine shop in West Stafford. In 1900 Stevens, with the expertise of optics designer and marksman Frederick L. Smith (1853-1930), also acquired a capability to manufacture telescopic sights, which after some resistance by conservative traditionalists, became generally accepted for competition.—But that's another story!

CONCLUSION

I regret that current time and space restrictions preclude my sharing notes and observations regarding many of the Valley's other 350 arms makers. We have not even begun to discuss the sword and bayonet makers, powder mill owners and operators, leather goods contractors, powder flask makers, and other individuals working in a variety of arms-related endeavors. We have only touched on three arms makers to any significant extent, but with what I hope you may regard as "fresh" insight.

SELECTED BIBLIOGRAPHY

Chandler, Nicholas L. "Fisher's Gun." Ottawa, Ontario: *Canadian Journal of Arms Collecting*, 1972.

Deyrup, Felicia Johnson. *Arms Making in the Connecticut Valley: A Regional Study of the Economic Development of the Small Arms Industry 1798-1870*. Northampton: Smiths College Studies in History, 1948. Reprint, York, PA: George Shumway, Publisher, 1970.

Havlin, Victor and Cheryl. *Mossberg, More Gun For The Money*. Minneapolis: Blue Book Publications, 1995.

Hicks, James E. *Notes On United States Ordnance, Vol. I, Small Arms, 1776 to 1946*. Mount Vernon, NY: privately published, 1946.

—*United States Ordnance, Vol. II, Ordnance Correspondence*. Mount Vernon, NY: privately published, 1940.

Laidacker, John S. *Developmental Cartridge Handguns in .22 Calibre, As Produced in The United States and Abroad From 1855 to 1875*. Bloomsburg, PA: Susquehanna House, 1994.

Lewis, Berkeley R. *Small Arms and Ammunition in the United States Service—1776-1865*. Washington, DC: Smithsonian Institution, 1956.

Logan, Herschel C. *Pictorial History of the Under-Hammer Gun*. New York: Castle Books, 1960.

Moller, George D. *Massachusetts Military Shoulder Arms 1784-1877*. Lincoln, Rhode Island: Andrew Mowbray, Inc., 1988.

—*American Military Shoulder Arms*. Vol. II. From the 1790s to the End of the Flintlock Period. Niwot, Colorado: University Press of Colorado, 1993.

Norton, Charles B. (comp.) *American Inventions and Improvements in Breech-Loading Small Arms, Heavy Ordnance, Machine Guns, Magazine Arms, Fixed Ammunition, Pistols, Projectiles, Explosives, and other Munitions of War, including a chapter on Sporting Arms*. Springfield: Chapin & Gould, 1860.

Patterson, C. Meade "George Elgin's Pistols." Madison, Wisconsin: *The Gun Collector*, 1949.

Puleo, Joseph V., Jr. "Notes on the Proof of New England Militia Muskets." *Man At Arms Magazine*, March/April 1985.

Rywell, Martin. *The Trial of Samuel Colt*. Harriman, TN: Pioneer Press, 1953.

Sellers, Frank M. and Samuel E. Smith. *American Percussion Revolvers*. Ottawa, Ontario: Museum Restoration Service, 1971.

Schmidt, Peter A. *U.S. Military Flintlock Muskets And Their Bayonets*. Woonsocket, RI: Andrew Mowbray Inc., Publishers, 2006.

Whittlesey, Derwent S. *The Springfield Armory*. Ph.D. Dissertation, Department of History, University of Chicago, 1920.

LOCAL HISTORY AND GENEALOGY

Burnham, W.E., et al., (comp.) *History and Tradition of Shelburne, Mass*. Shelburne: Town of Shelburne, 1958.

Carpenter and Morehouse. (comps.) *The History of the Town of Amherst, Massachusetts*. Amherst: Press of Carpenter & Morehouse, 1896.

Davenport, Elmer F. *As You Were Shelburne, Interesting Episodes in the History of Shelburne, Massachusetts.*

Day, James H. *Hatfield, Massachusetts 1670-1970.* Hatfield: Historical Commission, 1970.

Dewey, Louis Marinus. "Old Landmarks" in *Westfield Times and News Letter*, Jan. 2, 1895 to Oct. 6, 1897.

Everts, Louis H. *History of the Connecticut Valley in Massachusetts with Illustrations and Biographical Sketches of Some of its Prominent Men and Pioneers.* 2 Vols. Philadelphia: J.B. Lippincott & Co., 1879.

Green, Mason A. *Springfield 1636-1886, History of Town and City.* Springfield: C.A. Nichols & Co., 1888.

Holland, Josiah Gilbert. *History of Western Massachusetts; the Counties of Hampden, Hampshire, Franklin, and Berkshire.* 2 Vols. Springfield, MA, 1855.

Hutchinson, Fran Allen. (comp.) *Genealogical and Historical Sketches of the Allen Family of Dedham and Medfield, Massachusetts, 1637-1890.* Lowell: Privately printed, 1896.

Janes, Edward C. and Roscoe S. Scott, eds. *Westfield Massachusetts 1669-1969, The First Three Hundred Years.* Westfield: Westfield Tri-Centennial Assoc., Inc., 1969.

Jenkins, Paul. *A Social History of Greenfield Massachusetts.* Greenfield: Town of Greenfield, 1982.

King, Moses, ed. *King's Handbook of Springfield, Massachusetts. A Series of Monographs, Historical and Descriptive.* Springfield: James D. Gill, 1884.

Lockwood, John H. *Westfield and Its Historic Influences 1669-1919.* Westfield: Private printing, n.d.

McChesney, Herbert L. *A History of Ludlow Massachusetts 1774-1974.* Ludlow: Ludlow Bicentennial Committee, 1978.

Noble, Howard G. *Westfield, Massachusetts. A Trip Down Union Street from 1867 to 1894.* Westfield: unpublished paper, 1949.

Schlakman, Vera. "Economic History of a Factory

Town. A Study of Chicopee, Massachusetts." Northampton: *Smith College Studies in History.* Vol. XX, Nos. 1-4, October, 1934-July, 1935.

[Springfield Commerce and Manufacturing]. 1883 Commerce, Manufacturers & Resources, of Springfield, Mass. A Historical, Statistical & Descriptive Review. Springfield: National Publishing Co., 1883.

PRIMARY RECORDS

[American Fur Co.]. "Papers, Orders and Correspondence . . . 1831-49." New York Historical Society Library, New York.

[Ames Papers]. Correspondence, Contracts & Letter Books, 1727-1918. Connecticut Valley Historical Museum Archives, Springfield, MA

Hampden County Death Records

Hampden County Registry of Deeds—Book 100, pg. 188.

[Massachusetts Arms Co.]. *Contracts*, 1850-1859, *Letter Book*, Feb. 1850-Dec. 1852, *Cash Book*, Nov. 1849-May 1860, *Ledger*, Oct. 1849-Apr. 1868. Connecticut Valley Historical Museum Archives, Springfield, MA.

Massachusetts Census Index—1830, 1840.

PERIODICALS

Springfield Federal Spy

Springfield Daily Republican

Hampshire Gazette

Westfield Times and News Letter

SPRINGFIELD CITY DIRECTORIES

Bessey's *Springfield Directory of 1851-1852*

Skiff's *Springfield Almanac, Directory, and Business Advertiser, for 1845.*